

PC83-7 
REV. 7-06



ASSEMBLY AND OPERATION INSTRUCTIONS OWNER'S MANUAL

VEGETABLE DRILLS, SEEDERS,
TOOL BARS, AND ATTACHMENTS



Hand Seeder

LIMITED WARRANTY: Cole Planter Company offers a limited warranty on products it manufactures.



NOTICE: Cole Planter Company reserves the right to discontinue models at any time or change specifications, design or prices without notice and without incurring obligation.

COLE PLANTER COMPANY

P. O. Box 2 • Albany, Georgia 31702 • (229) 888-2032 • Fax (229) 888-0448 • www.coleplanter.com

SAFETY PROCEDURES



This safety-alert symbol identifies important safety messages in this manual. When you see this symbol, be alert to the possibility of personal injury and carefully read and follow the message that follows.



1. Lower the unit when adjusting it or doing maintenance work.



2. Always lower the unit from the transport position before detaching it from the tractor.



3. The implement should be operated by only those responsible and delegated to do so. Only one person should be on the tractor during operation: the operator. Do not allow anyone to ride on the implement.



4. Keep hands and loose clothing away from the moving parts when the implement is in operation.



5. Make sure that everyone is clear before starting the machine. Take special care of row markers.



6. Do not drive too fast on curves and hillsides or too close to ditches and creeks.



7. Do not try to operate the tractor unless you are in the driver's seat. Do not dismount while the tractor is in motion.



8. Check clearance before driving a planting unit under electric lines, bridges, or into buildings.



9. Comply with state and local laws when moving machinery on the highway. Use approved lights or warning devices.

CONTENTS

SECTION 1: Operation of Ground-Driven Drills

SECTION 2: Operation of Chain-Driven Hoppers

SECTION 3: Assembly of Hitches for Ground-Driven Drills

SECTION 4: Warranty

SECTION 1

ASSEMBLY AND OPERATION OF GROUND-DRIVEN DRILLS

891-928 Vegetable Drill with Floating Hitch
 871-358 Vegetable Drill
 873-098 Hand Seeder

A. PREPARE FOR OPERATION: 891-928 and 871-358 Vegetable Drills

Remove the two additional seed plates and other loose parts packed in the seed hopper. Go over all the bolts on the drill to make sure they are tight. Mount the drill to the tool bar or carrier. If you are using one of Powell's hitches or tool bar carriers, refer to Section 3 for instructions on assembly.

B. ASSEMBLY OF 873-098 HAND SEEDER

The 873-098 hand seeder comes in two parts: a carton containing the drill and other pieces, and the handle package including a right and left handle. The carton contains the following pieces: the assembled drill, row marker arm, the row marker weight, 3 seed plates, and envelope of bolts, the seed shutoff rod, the row marker cord, and wooden handle round. **ASSEMBLY HANDLES.**

Position the wooden handle round between the right and left handles as shown in Figure 1. Mount the end of the handles to the planter frame at the position shown, using two $\frac{3}{8}$ " x $1\frac{1}{2}$ " carriage bolts.

NOTE: Each handle is beveled on the end. The bevel should be turned to the inside when mounted.

Attach the handles to the handle braces using the $\frac{1}{4}$ " x $1\frac{1}{2}$ " carriage bolts. Adjust the handles to the proper height and tighten all bolts. On the right handle, install the eye bolt in the hole provided. On the left handle, install the J-bolt as shown. Refer to assembly drawing page 10.

INSTALL ROW MARKER.

Attach the row marker to the marker arm using the clamp halves, $\frac{1}{4}$ " to $1\frac{3}{4}$ " carriage bolt and wing nut. Refer again to Figure 1. Mount the row marker arm to the bracket over the wheel using the flat washer, spring and $\frac{1}{8}$ " x 1 " cotter pin. Place flat washer next to the cotter pin. Knot one end of the cord to the clamp on the row marker. Tie the other end around the wooden handle round.

INSTALL THE SEED SHUTOFF ROD.

Insert the seed shutoff rod through the eye bolt on the right handle. Hook the end through the seed shutoff lever at the hopper. Refer to Figure 1.

After the drill has been fully assembled, go over all the bolts to make sure that they are tight.

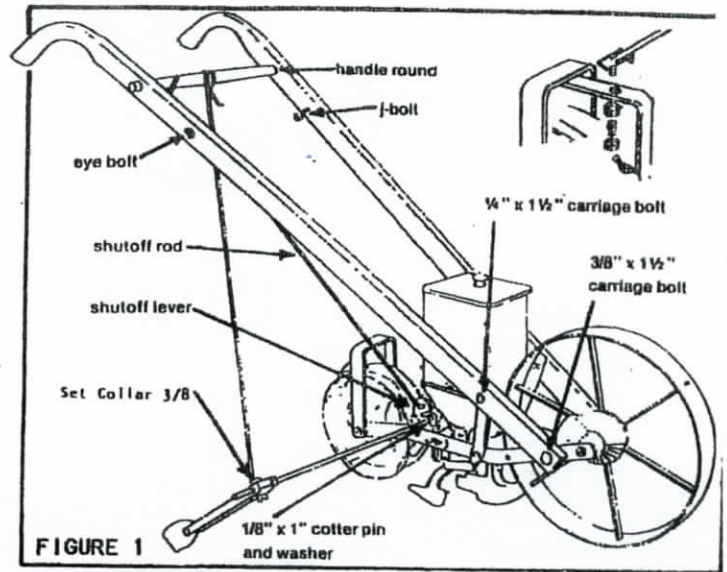

FIGURE 1

C. OPERATION OF GROUND-DRIVEN DRILLS

1. SEED SHUTOFF

All ground-driven drills are provided with a seed shutoff lever located on the right side of the hopper. When the lever is pushed forward, the seeder is open; when pulled back, it is closed. See Figure 2.

Models with the floating bracket automatically shutoff when the planting unit is raised.

The seed shutoff on the hand seeder is operated by means of the seed shutoff rod. When starting on the row, push the seed shutoff rod forward to open the shutoff mechanisms. When stopping at the end of the row, pull back toward you to close off the mechanism.

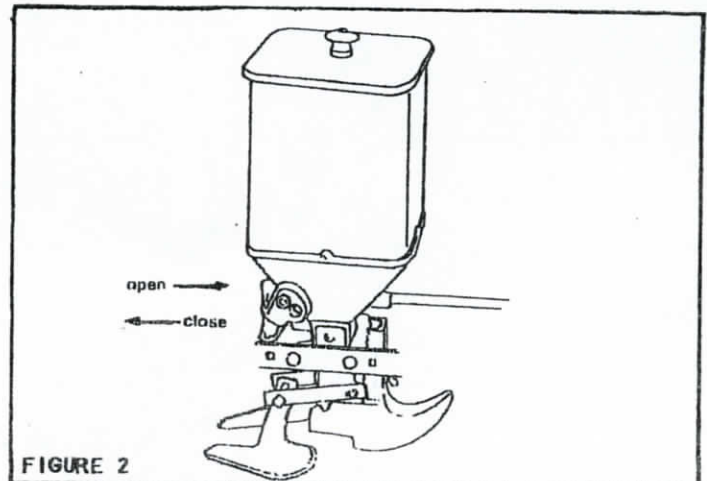
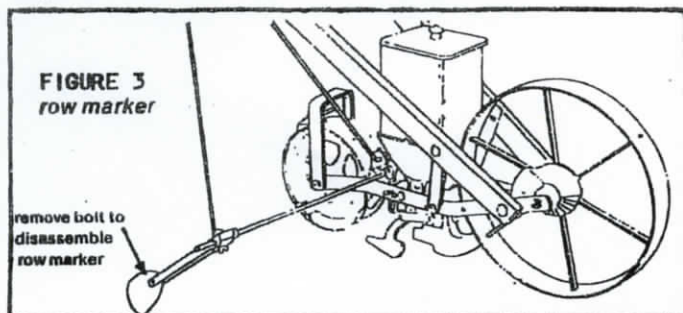

FIGURE 2

2. ROW MARKER ON HAND SEEDERS

The row marker has been designed so the it can be used in light or heavy soil with equally satisfactory results. Where the soil is heavy or where a deep mark is required, use the marker as you received it.

Where the soil is light, open the marker by removing the bolt and remove the inner cast weight from between the two marker halves. See Figure 3. Replace the two marker halves together.



3. COVER STOP PIECE

If it is desired to limit the amount of float of the coverer, adjust the coverer stop piece located on the left side of the planter frame. Loosen the bolt and slide the slotted steel piece either up or down as desired. See Figure 4.

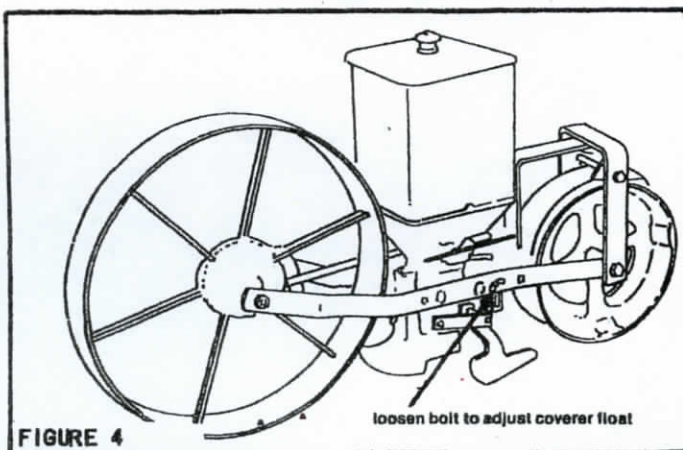

4. SEED PLATES

Three seed plates are furnished with every drill. Each plate has 13 holes or adjustments. The plate with the smallest holes, no. P00-5458, is shipped in place in the drill with no. 1 hole (smallest) in position. The other plates, no. P00-5459 with holes 14-26 and no. P00-5460 with holes 27-39 are shipped in the hopper lid.

TO DETERMINE THE CORRECT USED PLATE HOLE TO USE:

Refer to the chart for a list of commonly used seed. To the right of the seed will be the average number of seed sown to the foot, accompanied by the numbered hole that will sow that quantity of seed. This chart should be used only as a guide. Seeds of the same variety vary greatly in size, so you will need to test the drill with the seed that you intend to use.

From the chart, determine the hole for sowing the seed you desire. Set the seed plate with the hole indicated in position to sow. Place enough seed in the hopper to cover the feed wheel. Turn the front wheel so the rim travels about one foot. Check the amount of seeds dropped for proper distribution. More or less seed per foot may be achieved by moving the plate to a larger or smaller hole as required. As you find the correct hole for various seeds, make a note enabling you to set the seed plate quickly when planting the same seeds at a later date.

SEED PLATE SETTINGS		
SEED	HOLE NO.	SEED PER FOOT
beans	38	6
beet	22	22
cabbage	5	31
carrot	8	29
celery	3	75
cotton (delinted)	32	12
kale	4	16
kohl rabi	6	19
lettuce	12	36
onion	8	15
peas	38	15
parsnip	29	27
radish	13	28
salsify	35	13
spinach	12	10
turnip	1	18

Table is a guide only.
Determine correct hole by testing.

TO CHANGE HOLES ON A SEED PLATE:

Refer to Figure 5 on page 5.

- Loosen the cam slightly by moving the handle approximately 1" (25mm) toward the front of the seeder.
- Lift the flat spring until the pin is disengaged with the hole in the seed plate. (Do not pull this spring out.)
- Revolve the seed plate until the stamped number of the hole you wish to use comes opposite the pin in the flat spring.
- Tighten the cam by moving the handle toward the rear of the seeder.

TO CHANGE TO ANOTHER SEED PLATE:

- Loosen the cam by moving the handle toward the front of the drill.
- Lift and pull out the flat spring.
- Remove the cam and seed plate.
- The hopper may be entirely removed, if desired. Lift the hopper upward and to the rear until it is free of the spout.
- Replace the hopper. Place the end of the drive shaft in the bearing hole of the front wheel cover. Lower the hopper in place and push forward. See that the hopper is hooked on the pin on the right side of the spout.

- f. Insert the desired seed plate in position. Make sure the stamped numbers are on the upper side of the plate.
- g. Re-insert the cam.
- h. Replace the flat spring, making sure the pin is inserted in the index hole of the seed plate.
- i. Tighten the cam by turning the handle toward the rear of the drill.

NOTE: If difficulty is experienced in putting the cam back when changing seed plates, clean out all dirt that has lodged where the plate comes in contact with the seed opener in the bottom of the hopper.

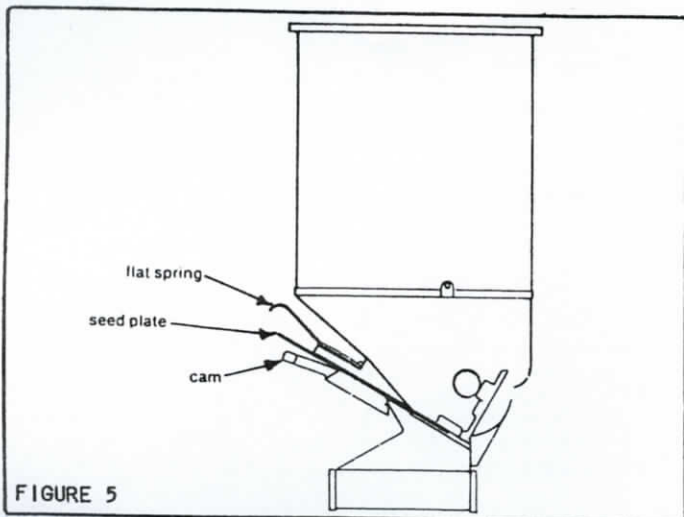

FIGURE 5

5. ADJUST OPENING FLOW.

The opening plow standard on ground-driven drills is the BOK-712 general purpose plow. The plow has a planting range of 0"-1 1/2" (0-38mm) deep. Other plows are available for various field conditions. See the list.

There are nine notches, 3/16" (5mm) apart, on the plow for depth adjustment. The first notch holds the plow above ground for shipping and transporting. The planting depth depends on a number of factors: kind of seed, time of year, moisture available, preparation of seedbed, etc. You should consider all factors before setting the plow. To adjust the plow, loosen the wing nut and slide the plow to the correct position. Tighten the wing nut with a pair of pliers. See Figure 6.

When starting to plant, check the planting depth by digging down the row until the seeds are located. It is better to make the necessary change at the start than to plant the entire field incorrectly.

Plows sometime wear rapidly due to the grinding effect of sand in the soil. They should be inspected occasionally and set deeper as wear occurs. When it is necessary to replace one plow on a multi-row unit, replace plows on all drills.

OTHER PLOWS AVAILABLE ARE:

- BOK-812: deep general purpose shoe for planting 1"-2 1/2" (25-63mm) deep.
 - BOK-762: shallow upland shoe for planting 0"-1 1/2" (0-38mm) deep in hard soil.
 - BOK-798: deep upland shoe for planting 1"-2 1/2" (25-63mm) deep in hard soil.
 - BOK-783: 2" wide scatter shoe for planting 0"-1 1/2" (0-38mm) deep.
 - BOK-769: 4" wide scatter shoe for planting 0"-1 1/2" (0-38mm) deep.
- ALSO AVAILABLE: B10-039x narrow brush feed wheel for handling delicate seeds.

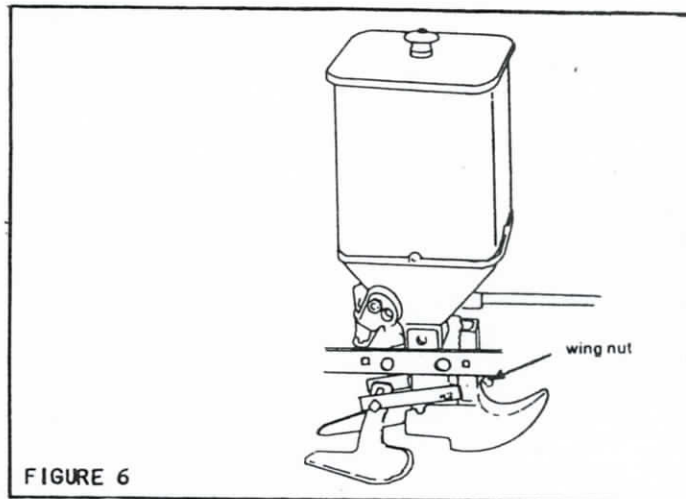

FIGURE 6

6. PINION DRIVE GEAR INSTALLATION.

Install Pinion Drive Gear with Set Screws on drive shaft. Engage the pinion drive gear with the gear on the drive wheel. Tighten the set screws. Spin the wheel to make sure the gears mesh properly and the wheel spins freely. If the gears do not mesh properly, loosen the set screws and readjust.

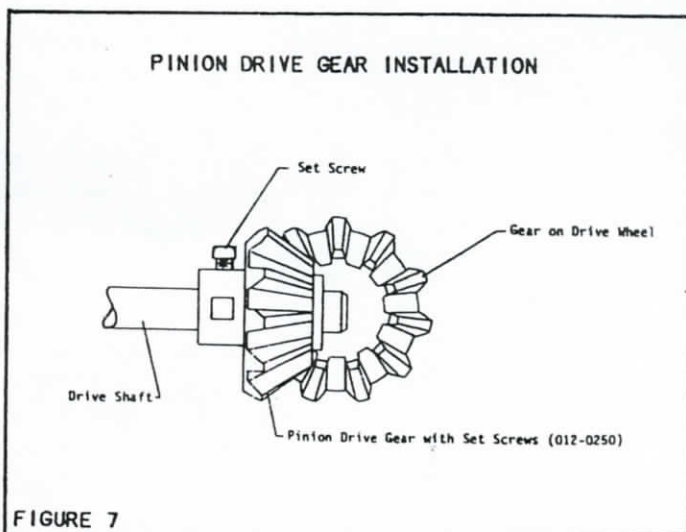

FIGURE 7

SECTION 2

ASSEMBLY AND OPERATION OF CHAIN-DRIVEN HOPPERS

MODEL B10-781X SINGLE SPOUT HOPPER
MODEL B81-97X DOUBLE SPOUT HOPPER

A. ASSEMBLY OF CHAIN-DRIVEN HOPPERS

The hopper carton contains the following: the hopper lid, the assembled hopper, three seed plates, the hopper plate and shutoff, the spout assembly, and a bag containing two sprockets, a spring, bolts, and hardware.

1. MOUNT HOPPER PLATE IMPLEMENT.

Refer to Figure 8. Mount the hopper plate to the implement or carrier using the two 3/8" x 1 1/4" carriage bolts and tapered washers.

2. MOUNT HOPPER AND SPOUTS TO HOPPER PLATE.

Remove the 1/4" x 1" carriage bolt from the hopper base. Position the hopper on the hopper plate and hold the spout assembly under the plate. Bolt these assemblies together using two 1/4" x 1 1/2" Hex Hd Bolts through the hopper, hopper plate, and spout assembly. Refer to Figure 8.

3. ATTACH THE 8-POINT SPROCKET.

Attach the 8-point sprocket to the drive shaft on either side of the hopper as desired, using the 1/8" x 1 1/4" cotter pin.

A 10-point split sprocket with a set of shims is provided to attach to your drive mechanism.

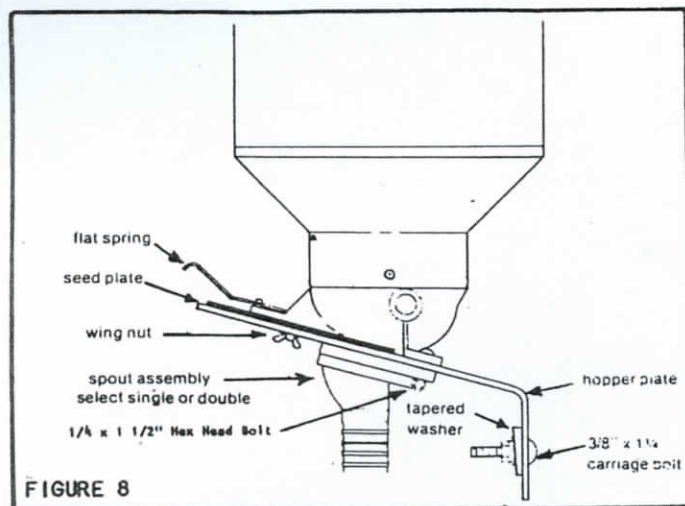

FIGURE 8

B. SEED PLATES

Chain-driven hoppers are provided with a shut-off plate. When the plate is pushed in, the seed flow is cut off. When the plate is pulled out, the hopper is open.

C. SEED PLATES

Three seed plates are furnished with each hopper. Single spout plates have 13 adjustments and holes per plate. Double spout plates have a total of 36 adjustments and pairs of holes for all 3 plates.

TO DETERMINE THE CORRECT SEED PLATE HOLE TO USE:

Refer to the chart below for a table of commonly used seed. To the right of the seed name will be the average number of seed sown to the foot per row, accompanied by the numbered hole that will sow that quantity of seed. This chart should be used only as a guide. Seeds of the same variety vary greatly in size, so you will need to test the hopper with the seed you intend to use.

From the chart, determine the suggested hole for sowing the seed you have. Set seed plate with the hole indicated in position to sow. Place enough seed in the hopper to cover the feed wheel. Check the amount of seeds dropped for proper distribution. More or less seeds per foot may be achieved by moving the plate to a larger or smaller hole as required. As you find the correct hole for various seeds, make a note of the hole number enabling you to set the seed plate quickly when planting the same seeds later. When the correct hole has been found on one hopper, all the hoppers on the unit may be set to the same hole with the same results.

SEED PLATE SETTINGS		
SEED	HOLE NO.	SEED PER FOOT
beans	38	6
beet	22	22
cabbage	5	31
carrot	8	29
celery	3	75
cotton (delinted)	32	12
kale	4	16
kohlrabi	6	19
lettuce	12	36
onion	8	15
peas	38	15
parsnip	29	27
radish	13	28
salsify	35	13
spinach	12	10
turnip	1	18

Table is a guide only.
Determine correct hole by testing.

SECTION 3

ASSEMBLY OF HITCHES FOR GROUND-DRIVEN DRILLS

TO CHANGE HOLES ON A SEED PLATE:

Refer to Figure 9.

- Loosen the wing nut on the seed plate pin.
- Lift the flat spring until the pin is disengaged with the hole in the seed plate. (Do not pull the flat spring out.)
- Revolve the seed plate until the stamped number of the hole you wish to use comes opposite the pin in the flat spring.
- Retighten the wing nut on the seed plate pin.

TO CHANGE TO ANOTHER SEED PLATE:

- Remove the wing nut on the seed plate pin.
- Lift the flat spring until the pin is disengaged and pull the flat spring out.
- Slide out the seed plate pin.
- Remove the seed plate and install the seed plate that you wish to use.
- Push the seed plate pin back up through the seed plate.
- Engage the flat spring in the groove of the seed plate pin and engage the spring in one of the index holes of the seed plates.
- Re-install the wing nut on the seed plate pin and tighten it.

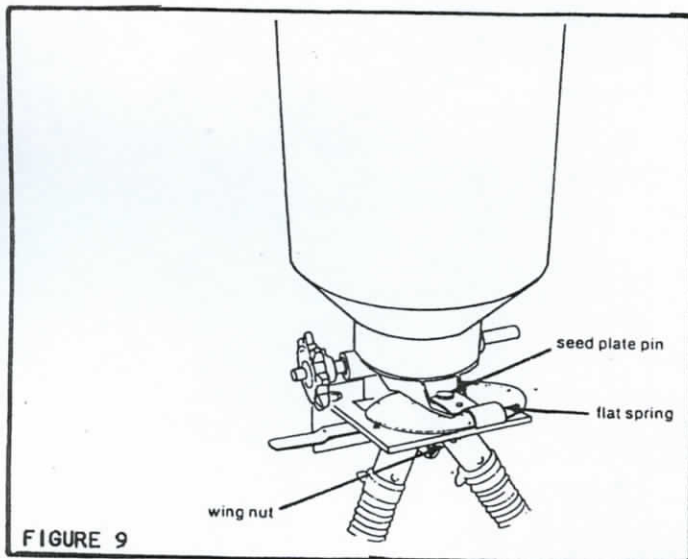

1. B21-259 HITCH WITH VERTICAL ADJUSTMENT FOR MOUNTING TO 2 1/2" CORNER-MOUNTED TOOL BARS.

Refer to Figure 10. Mount the hitch standard to the front of the floating bracket using two 1/2" x 1 1/2" machine bolts, lock washers and nuts. Slide the clamp onto the stem of the standard and tighten the two 1/2" x 2 1/4" machine bolts.

Starting at the center of the tool bar, mark the proper row spacing on the bar. Position the drill behind the tool bar so that the center of the opening foot is at the row spacing mark. Mount the drill to the tool bar as shown, using the clamp plate, washers, and nuts. When you are in the field ready to begin planting, adjust the tool bar to operating height. Then adjust the clamp on the hitch of each drill, so that the floating bracket will be parallel to the ground at normal operating position.

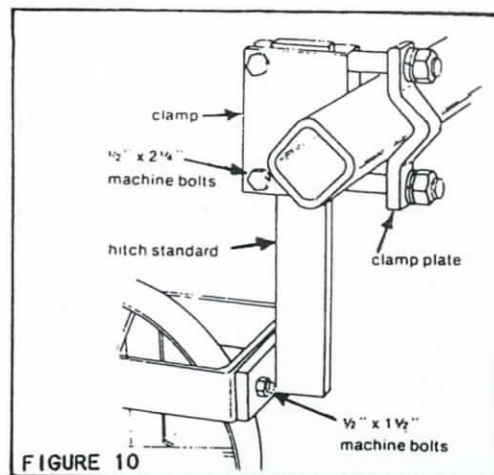

2. B21-261 HITCH WITH VERTICAL ADJUSTMENT TO MOUNT TO 2 1/2" SQUARE-MOUNTED TOOL BARS.

Mount the hitch standard to the front of the floating bracket using the two 1/2" x 1 1/2" machine bolts, lock washers, and nuts. Refer to Figure 11. Slide the clamp onto the standard as shown, and tighten the two 1/2" x 2 1/4" machine bolts.

Starting at the center of the tool bar, measure and mark the proper row spacing on the bar. Position the drill behind the tool bar so that the center of the opening foot is at the row mark. Mount the drill to the tool bar using the two U-bolts, lock washers, and nuts. When you are in the ready to begin planting, adjust to tool bar to operating height. Then adjust the clamp on the hitch of each planter, so that the floating bracket will be parallel to the ground at normal operating position.

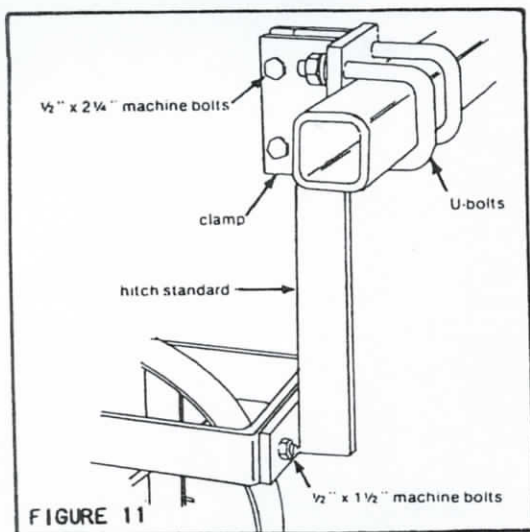

FIGURE 11

3. B21-263 HITCH WITH VERTICAL ADJUSTMENT TO MOUNT TO 4" x 4" TOOL BAR.

Mount the hitch standard to the front of the floating bracket, as shown in Figure 12. Use two 1/2" x 1 1/2" machine bolts, lock washers, and nuts. Slide the clamp onto the standard and tighten the two 1/2" x 2 1/4" machine bolts.

Starting at the center of the tool, measure and mark the row spacing on the tool bar. Position the drill behind the tool bar so that the center of the opening foot is at the row mark. Mount the drill to the tool bar using the two U-bolts, lock washers, and nuts. Adjust the tool bar to the operating height. Then adjust the clamp on the hitch of each drill, so that the floating bracket will be parallel to the ground at normal operating position.

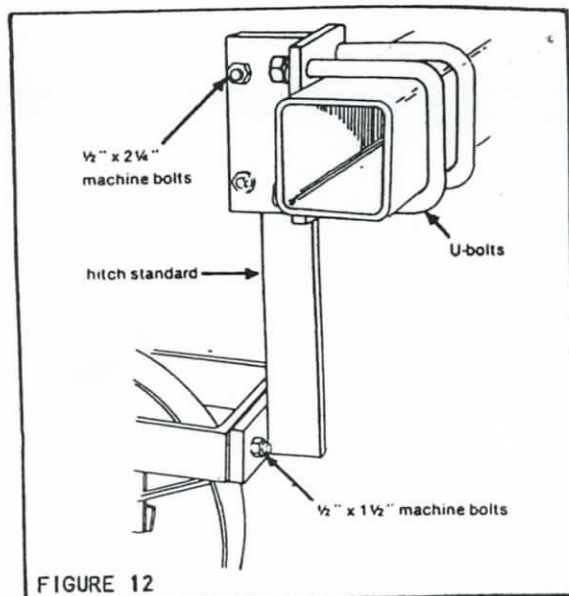

FIGURE 12

4. B21-264 HITCH WITH VERTICAL ADJUSTMENT TO MOUNT TO REAR-ANGLE FRAME CULTIVATORS.

Mount the hitch standard to the front of the floating bracket as shown in Figure 13, using two 1/2" x 1 1/2" machine bolts, lock washers, and nuts. Slide the clamp onto the standard and tighten the two 1/2" x 2 1/4" machine bolts.

Measuring from the center of the cultivator, mark the row spacing on the frame. Position the drill under the frame so that the center of the opening foot is at the row mark. Mount the drill to the cultivator frame using two 7/16" x 1 1/2" machine bolts, lock washers, and nuts. When you are in the field ready to begin planting, adjust the cultivator to its correct operating height. Then adjust the clamp on the hitch of each drill so that the floating bracket will be parallel to the ground at normal operating position.

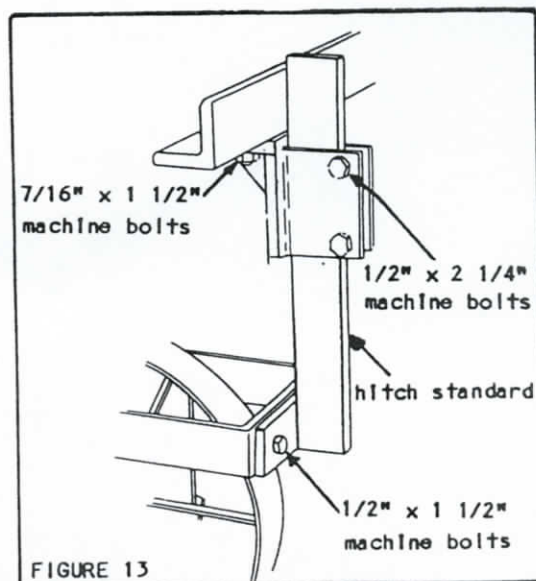
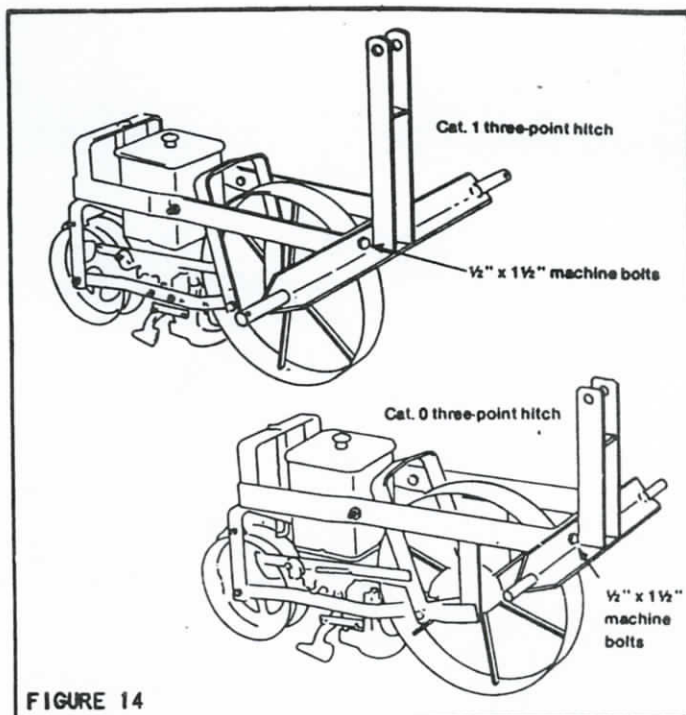

FIGURE 13

**5. B47-047 CATEGORY 0 THREE-POINT HITCH AND
B21-305A CATEGORY 1 THREE-POINT HITCH.**

Refer to Figure 14. Mount the three-point hitch to the front of the floating bracket, as shown, using the two 1/2" x 1 1/2" machine bolts, lock washers, and nuts.

Before planting make these adjustments. With the planter attached to your tractor's three-point hitch, lower the planter to planting position. Adjust the top link of the tractor's three-point hitch so that the top link mask of the planter hitch is at a right angle to the ground. This can be checked by viewing the unit from the side.



PLANET JR. ACCESSORIES

I. 2 1/2" Corner Mounted Tool Bars and Attachments

A. 2 1/2" CORNER MOUNTED TOOL BARS

- 80", 1/4" wall, Cat. I
- 144", 1/4" wall, Cat. II
- 160", 1/4" wall, Cat. II
- 240", 1/4" wall, Cat. II

B. ATTACHMENTS FOR 2 1/2" CORNER MOUNTED TOOL BARS

- Track Eradicators
- Gauge Wheels
- Row Markers

II. 4" x 4" TOOL BARS AND ATTACHMENTS

A. 4" x 4" TOOL BARS

- 80", 1/4" wall, Cat. I
- 160", 1/4" wall, Cat. II
- 180", 1/4" wall, Cat. II/III
- 240", 1/4" wall, Cat. II/III

B. ATTACHMENT FOR 4" x 4" TOOL BARS

- Track Eradicators
- Gauge Wheels
- Pull type kit for tool bars
- Hydraulic row markers

III. DOUBLE 4" x 4" TOLL BARS AND ATTACHMENTS

A. DOUBLE 4" x 4" TOOL BARS

- 80", Cat. I
- 160", Cat. II
- 180", Cat. II/III
- 240", Cat. II/III

B. ATTACHMENTS FOR DOUBLE 4" x 4" TOOL BARS

- Track Eradicators
- Gauge Wheels
- Pull type kit for tool bars
- Fertilizer attachments

See your local dealer for these accessories.

REPAIR PARTS

B 73-09B Hand Seeder

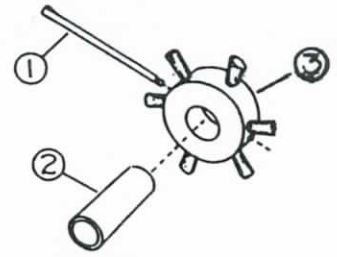

BUNDLE B10-039X: NARROW BRUSH FEED WHEEL
FOR SINGLE HOPPER
BUNDLE B96-084X: WIDE BRUSH FEED WHEEL
FOR DOUBLE HOPPER

REF. NO.	PART NO.	DESCRIPTION	NO. REQ.
1	001-3355	Cotter Pin 1/8" x 2"	1
2	P00-521A	Ferrule	1
3	P96-083	Brush, Narrow Feed Wheel	1
	P96-084	Brush, Wide Feed Wheel (Not Shown)	1

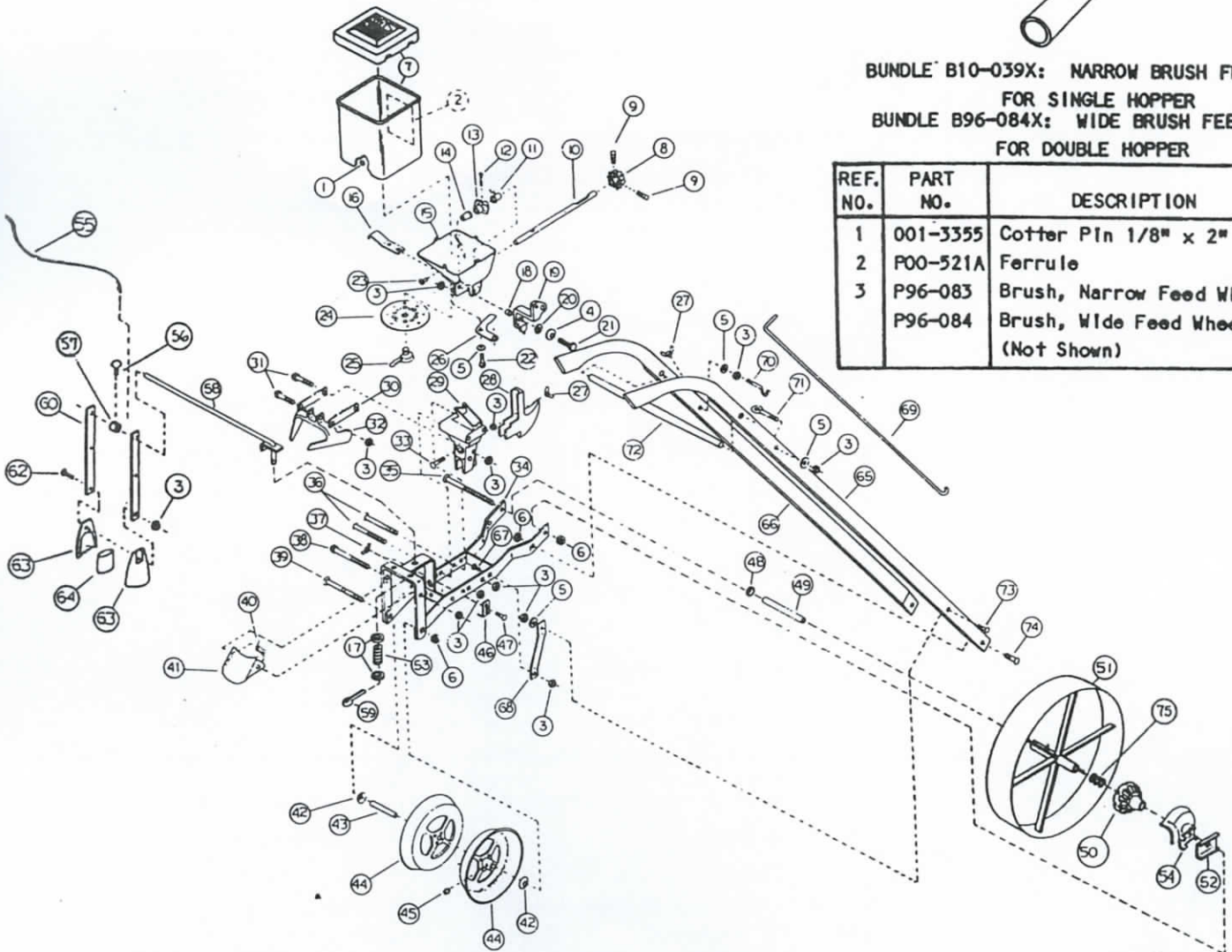

DIAGRAM NUMBER	PART NUMBER	DESCRIPTION	NUMBER PER ASSEMBLY
1	001-1047	Washer, 1/8 Pop Rivet .312 x .129 x .030	12
2	003-5598	Decal, Powell/Cole Planet Jr.	1
3	001-0054	Locknut, Hex ZP 1/4-20NC	15
4	P21-304	Washer, Belleville	1
5	001-1001	Washer, Flat ZP 1/4" USS STD Wrought	5
6	001-0055	Locknut, Hex ZP 3/8-16NC	4
7	P21-458	Hopper and Lid Assembly/Plastic, Square	1
	B21-326A	Hopper, Seed W/Shaft Assembly	1
8	004-4605	Gear, Pinion Drive (Order 012-0250 Kit)	1
9	001-2751	Screw, Set Sq. Hd ZP 1/4 x 1/2	2
10	016-5000	Shaft, Drive Planet Jr.	1

<u>DIAGRAM</u> <u>NUMBER</u>	<u>PART</u> <u>NUMBER</u>	<u>DESCRIPTION</u>	<u>NUMBER</u> <u>PER ASSEMBLY</u>
11	P00-519A	Bushing, Nylon 13/16" Lg.	1
12	001-3332	Pin, Cotter ZP 1/8 x 1-1/4	1
13	POK-817T	Plastic Feed Wheel	1
14	P00-520A	Bushing, Nylon 1-5/16" Lg.	1
15	POK-717C	Base, Hopper	1
<div style="border: 1px solid black; padding: 5px; display: inline-block;"> Replaced with B10-D39X </div> <div style="margin-left: 20px;"> No Longer Available </div>			
16	B00-6542-X	Latch, Seed Plate	1
17	001-1003	Washer, Flat 3/8, ZP USS STD Wrought	2
18	P21-270	Bushing	1
19	POK-719A	Lever, Seed Shut Off	1
20	P21-323	Wavey Spring Washer	1
21	001-2035N	Screw, Cap Hex Hd NY-Lock 5/16" x 1"	1
22	001-2004	Screw, Cap Hex Hd ZP 1/4-20NC x 3/4"	1
23	001-3509	Rivet, Pop 1/8" x .400 Lg. Aluminum	12
24	P00-5458	Plastic Seed Plate #1, 1-13	1
	P00-5459	Plastic Seed Plate #2, 14-26	1
	P00-5460	Plastic Seed Plate #3, 27-39	1
25	POK-740	Cam, Hopper Support	1
26	P00-5441	Shut Off, Seed	1
27	001-0100	Nut, Wing, ZP 1/4-20	2
28	BOK-712	Shoe, Drill	1
29	POK-835	Seed Spout	1
30	P00-5482	Arm, Cover	2
31	001-2012	Screw, Cap HH ZP 1/4-20NC x 2-1/2	2
32	B00-6540-X	Cover, Seed, W/Arm, P.J.	1
33	001-2554	Bolt, Crg., ZP 1/4-20NC x 1-1/2	1
34	P21-272	Weldment, Main Frame	1
35	001-2616	Bolt, Crg 3/8-16NC X 7	1
36	001-2565	Bolt, Crg., ZP 1/4-20NC x 4-1/2	2
37	001-0100	Nut, Wing, ZP 1/4-20	1
38	001-2020	Screw, Cap Hex Hd., ZP 1/4-20NC x 5"	1
39	001-2611	Bolt, Crg., ZP 3/8-16NC x 5"	1
40	P00-7207	Coil Springs	1
41	P00-5441	Scraper	1
42	P00-3806	Cap, Dust	2
43	P00-5473	Ferrule, Roller	1
44	POK-894	Wheel, Rear Roller	2
45	003-8523	Fitting, Grease Straight 1/4" Drive	2
46	P00-5486	Piece, Stop	1
47	001-2551	Bolt, Crg., 1/4 x 3/4	1
48	P00-3806	Cap, Dust	1
49	P00-4910	Ferrule, Wheel	1
50	POK-713C	Cast Wheel Hub	1

<u>DIAGRAM NUMBER</u>	<u>PART NUMBER</u>	<u>DESCRIPTION</u>	<u>NUMBER PER ASSEMBLY</u>
51	P21-234A B06-533X-A	Drive Wheel Weld Assembly For Iron Hub Kit, Drive Wheel (Cast Iron)	1 1
52	P21-298	Spacer	1
53	P21-322	Compression Spring	1
54	POK-721C	Gear Cover	1
55	POO-5258	Cord For Row Marker	1
56	001-3310	Screw Thumb 1/4-20 NC X 1"	1
57	004-5251	Set Collar 3/8	1
58	P21-521	Marker Rod	1
59	001-3351	Cotter Pin 1/8 x 1	1
60	POO-5096	Arm, Marker	2
63	POK-730	Marker Half	2
64	POK-729	Marker Weight	1
	B00-6543-X	Arm, Row Marker W/Weight	1
65	POW-1115-R	Wooden Handle, Right	1
66	POW-1115-L	Wooden Handle, Left	1
67	001-2551	Bolt, Crg., ZP 1/4-20NC x 3/4	2
68	POO-5443	Brace, Handle	2
69	POO-5475	Shut-Off Rod	1
70	P29-560	J-Bolt, 1/4 x 2-1/2	1
71	P29-720	Eye Bolt, Closed, 1/4 x 2	1
72	POO-W148	Round Handle	1
73	001-2554	Bolt, Crg., ZP 1/4-20NC x 1-1/2	2
74	001-2559	Bolt, Crg., ZP 3/8-16NC x 1-1/2	2
75	003-8808	Spring	1

REPAIR PARTS

B91-92B Vegetable drill with floating hitch

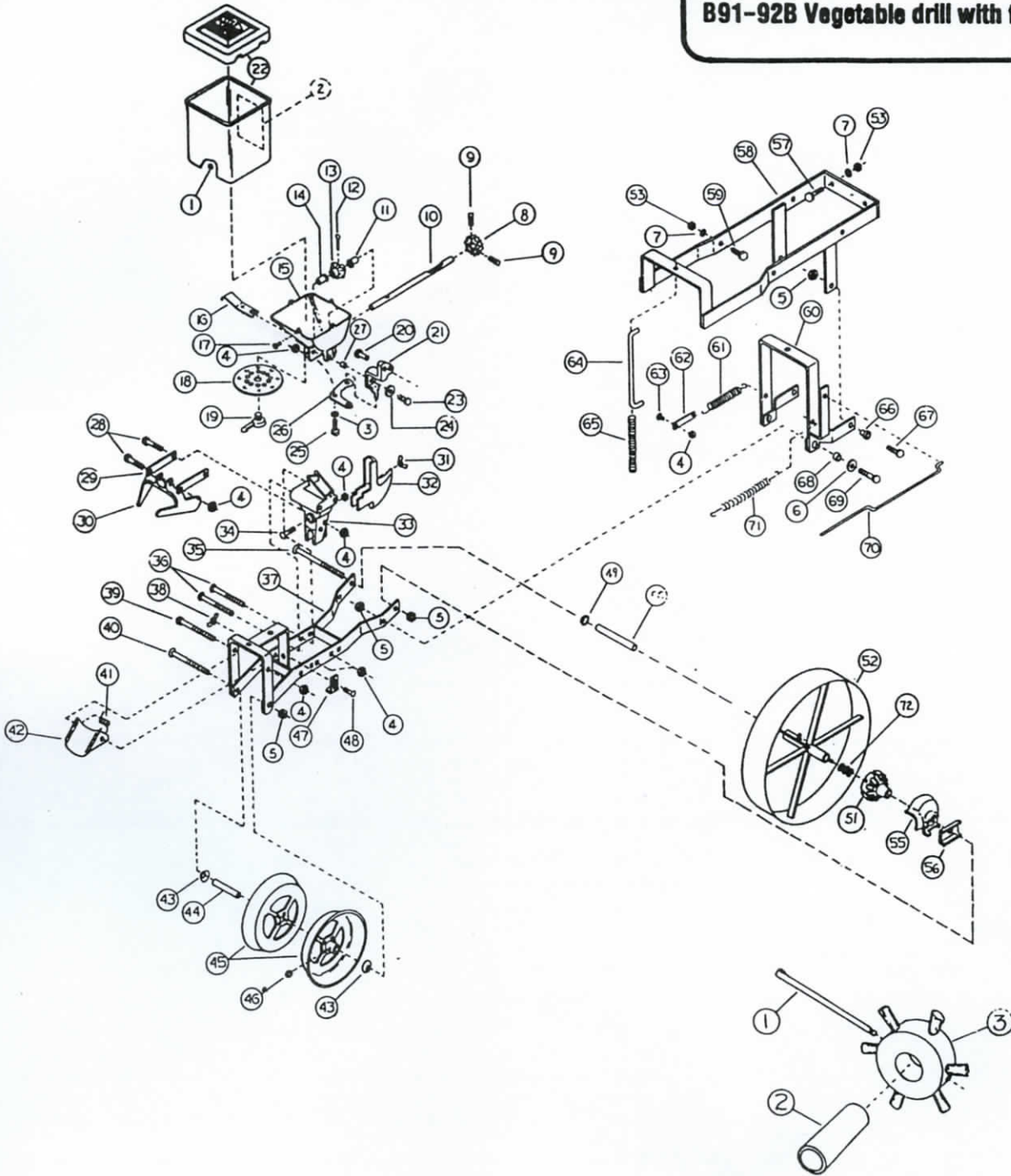

BUNDLE B10-039X: NARROW BRUSH FEED WHEEL
FOR SINGLE HOPPER
BUNDLE B96-084X: WIDE BRUSH FEED WHEEL
FOR DOUBLE HOPPER

REF. NO.	PART NO.	DESCRIPTION	NO. REQ.
1	001-3355	Cotter Pin 1/8" x 2"	1
2	P00-521A	Ferrule	1
3	P96-083	Brush, Narrow Feed Wheel	1
	P96-084	Brush, Wide Feed Wheel (Not Shown)	1

<u>DIAGRAM</u> <u>NUMBER</u>	<u>PART</u> <u>NUMBER</u>	<u>DESCRIPTION</u>	<u>NUMBER</u> <u>PER ASSEMBLY</u>
1	001-1047	Washer, 1/8 Pop Rivet .312 x .129 x .030	12
2	003-5598	Decal, Powell/Cole Planet Jr.	1
3	001-1001	Washer, Flat 1/4", ZP USS STD. Wrought	1
4	001-0054	Locknut, Hex ZP 1/4"	8
5	001-0055	Locknut, Hex ZP 3/8"	6
6	001-1002	Washer, Flat 5/16" ZP USS STD Wrought	2
7	001-1254	Washer, Lock ZP 1/2"	4
8	004-4605	Gear, Pinion Gear (Order 012-0250 Kit)	1
9	001-2751	Screw, Set Sq. Hd. ZP 1/4 x 1/2	2
10	016-5000	Shaft, Drive	1
11	P00-519A	Bushing, Nylon 13/16" Lg.	1
12	001-3352	Pin, Cotter ZP, 1/8 x 1-1/4	1
13	POK-817T	Plastic Feed Wheel	1
14	P00-520A	Bushing, Nylon 1-5/16" Lg.	1
15	POK-717C	Base, Hopper	1
<div style="display: flex; justify-content: space-around; align-items: center;"> <div style="border: 1px solid black; padding: 5px; transform: rotate(-15deg);"> <p>Replaced with B10-039X</p> </div> <div style="border: 1px solid black; padding: 5px; transform: rotate(15deg);"> <p>No Longer Available</p> </div> </div>			
16	B00-6542-X	Latch, Seed Plate	1
17	001-3509	Rivet, Pop 1/8" x .400 Lg. Aluminum	12
18	P00-5458	Plastic Seed Plate 1-13	1
	P00-5458M	Metal Seed Plate 1-13	1
	P00-5459	Plastic Seed Plate 14-26	1
	P00-5459M	Metal Seed Plate 14-26	1
	P00-5460	Plastic Seed Plate 27-39	1
	P00-5460M	Metal Seed Plate 27-39	1
	B21-517	Set of (3) Three Metal Seed Plates (1-13), (14-26), (27-39)	1
19	POK-740	Cam Casting	1
20	P21-319	Pin, Clevis	1
21	POK-719A	Lever, Seed Shut-Off	1
22	P21-458	Hopper and Lid Assembly/Plastic, Square	1
	B00-7559-B	Plastic Hopper and Shaft Assembly	1
23	001-2035N	Screw, Cap Hex Hd NY-Lock 5/16" x 1"	1
24	001-1002	Washer, Flat 5/16" ZP USS STD Wrought	1
25	001-2004	Screw, Cap HH ZP 1/4-20NC x 3/4"	1
26	P00-5441	Shut-Off, Seed	1
27	P21-270	Bushing	1
28	001-2012	Screw, Cap HH ZP 1/4-20NC x 2-1/2"	2
29	P00-5482	Arm, Cover	2
30	B00-6540-X	Cover, Seed, W/Arm	1
31	001-0100	Nut, Wing, ZP 1/4-20	1
32	BOK-712	Shoe, Drill	1
33	POK-835	Seed Spout	1
34	001-2554	Bolt, Crg., ZP 1/4-20NC x 1-1/2"	1
35	001-2616	Bolt, Crg 3/8-16NC x 7	1

<u>DIAGRAM NUMBER</u>	<u>PART NUMBER</u>	<u>DESCRIPTION</u>	<u>NUMBER PER ASSEMBLY</u>
36	001-2565	Bolt, Crg., ZP 1/4-20NC x 4-1/2"	2
37	P21-272	Weldment, Main Frame	1
38	001-0100	Nut, Wing, ZP 1/4"-20	1
39	001-2020	Screw, Cap HH ZP 1/4-20NC x 5"	1
40	001-2611	Bolt, Crg., ZP 3/8-16NC x 5"	1
41	P00-7207	Coil Spring	1
42	P00-5541	Scraper	1
43	P00-3806	Cap Dust	2
44	P00-5473	Ferrule, Roller	1
45	POK-894	Rear Roller Cast Wheel	2
46	003-8523	Fitting, Grease Straight 1/4" Drive	2
47	P00-5486	Piece, Stop	1
48	001-2551	Bolt, Crg., 1/4" x 3/4"	1
49	P00-3806	Cap, Dust	1
50	P00-4910	Ferrule, Wheel	1
51	POK-713C	Cast Wheel Hub	1
52	P21-234A B06-533X-A	Drive Wheel Weld Assembly For Iron Hub Kit, Drive Wheel	1 1
53	001-0009	Nut, Hex ZP 1/2-13NC	4
54			
55	POK-721C	Gear Cover	1
56	P21-298	Spacer	1
57	001-2121	Screw, Cap HH ZP 1/2-13NC x 1-1/2	2
58	P21-278	Weldment, Floating Hitch	1
59	001-2119	Screw, Cap HH 1/2-13NC x 1	2
60	P09-179X-A	Ball and Link Weld Assembly	1
61	P00-5587	Coil Spring	1
62	P21-301	Tension Spring Adjuster	1
63	001-2551	Bolt, Crg., ZP 1/4-20NC x 3/4	1
64	P21-284	Pin, Spring Guide	1
65	P21-152	Coil Spring	1
66	P0T-227	Ferrule	2
67	001-2066	Screw, Cap HH ZP 3/8-16NC x 1-1/4	2
68	PSD-42	45/64" x 13/32" x 21/32" Hardened Bushing	2
69	001-2067	Machine Bolt, 3/8" x 1-1/2"	2
70	P21-288	Arm, Seed Shut-Off	1
71	P21-289	Coil Spring	1
72	003-8808	Spring	1