

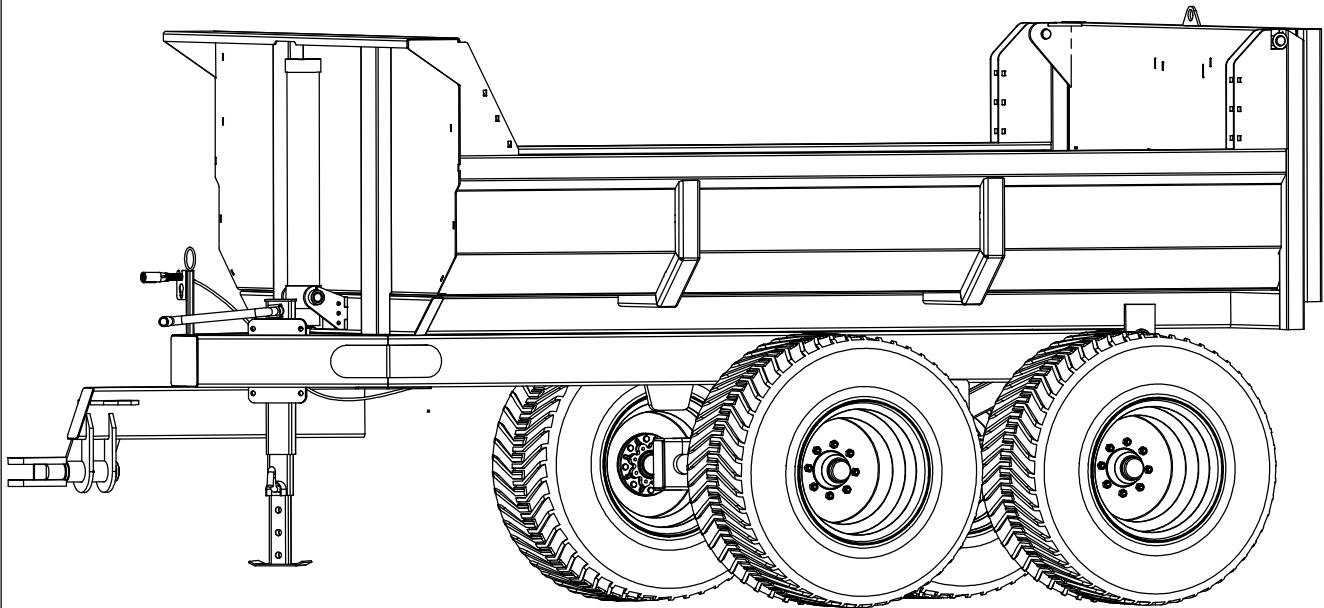

Woody Dump Trailer, V series

Models:

407- 408 - 510 610- 612-
712- 814- 816



Les Équipements Woody inc. 205, rue commercial Saint-Odilon, Québec G0S3A0

Tél./ Tel. 418-464-2748 Fax. 418-464-2746

Courriel/Email: ewoody@sogetel.net Site Web/ Website : www.equipementswoody.com

Facebook: Les Équipements Woody



Woody Equipment Inc.
Owners: Jerome et Sebastien Labbe

205 rue commerciale
St-Odilon de cranbourne
Beauce-Nord
Quebec, Canada
G0S 3A0

T. (418) 464-2748
F. (418) 464-2746

Email : ewoody@sogetel.net
Website: www.equipementswoody.com
Facebook: Les Equipements Woody

Woody Equipment Inc.

© All Rights Reserved: Woody Equipment inc. of Saint-Odilon-de -ranbourne.
No part of this manuel may be reproduced in any form without the written permission of Woody Equipment Inc.



Table of Contents

Introduction.....	1
Warning.....	2
Dump Trailer, model 407 Parts List.....	3
Dump Trailer, model 408 Parts List.....	4
Dump Trailer, model 510 Parts List.....	5
Dump Trailer, model 610 Parts List.....	6
Dump Trailer, model 612 Parts List.....	7
Dump Trailer, model 712 Parts List.....	8
Dump Trailer, model 814 Parts List.....	9
Dump Trailer, model 816 Parts List.....	10
Dump trailer Gravel box extensions.....	11
Dump trailer Gravel box high extension.....	12
Safety Operation.....	13
Safety Instructions.....	14-19
Warranty.....	20-21



Introduction

Congratulations on your purchase of a Woody Dump Trailer. Woody Equipment designs and manufactures equipment according to very strict criteria. This equipment is intended for professional use in the agricultural and forestry sectors.

Even if you have experience with this type of product, we recommend that you read these instructions carefully. These instructions contain important information on safety and efficiency and to ensure the validity of the factory guarantee.

Woody Equipment reserves the right to modify and / or improve its equipment and maintenance instructions, as well as to revise data without notice.

Write down the serial number, model number, purchased date, dealer name, and sales representative's name. Keep this information available for ordering parts as well as for any technical assistance or warranty issue.

Serial number	
Model number	
Purchased date	
Dealer	
Sales representative	



Warning

The following symbols used in this manual are to warn the operator of the dangers connected to the use of this machinery. Follow the safety instructions to avoid any risk of serious injury or death.

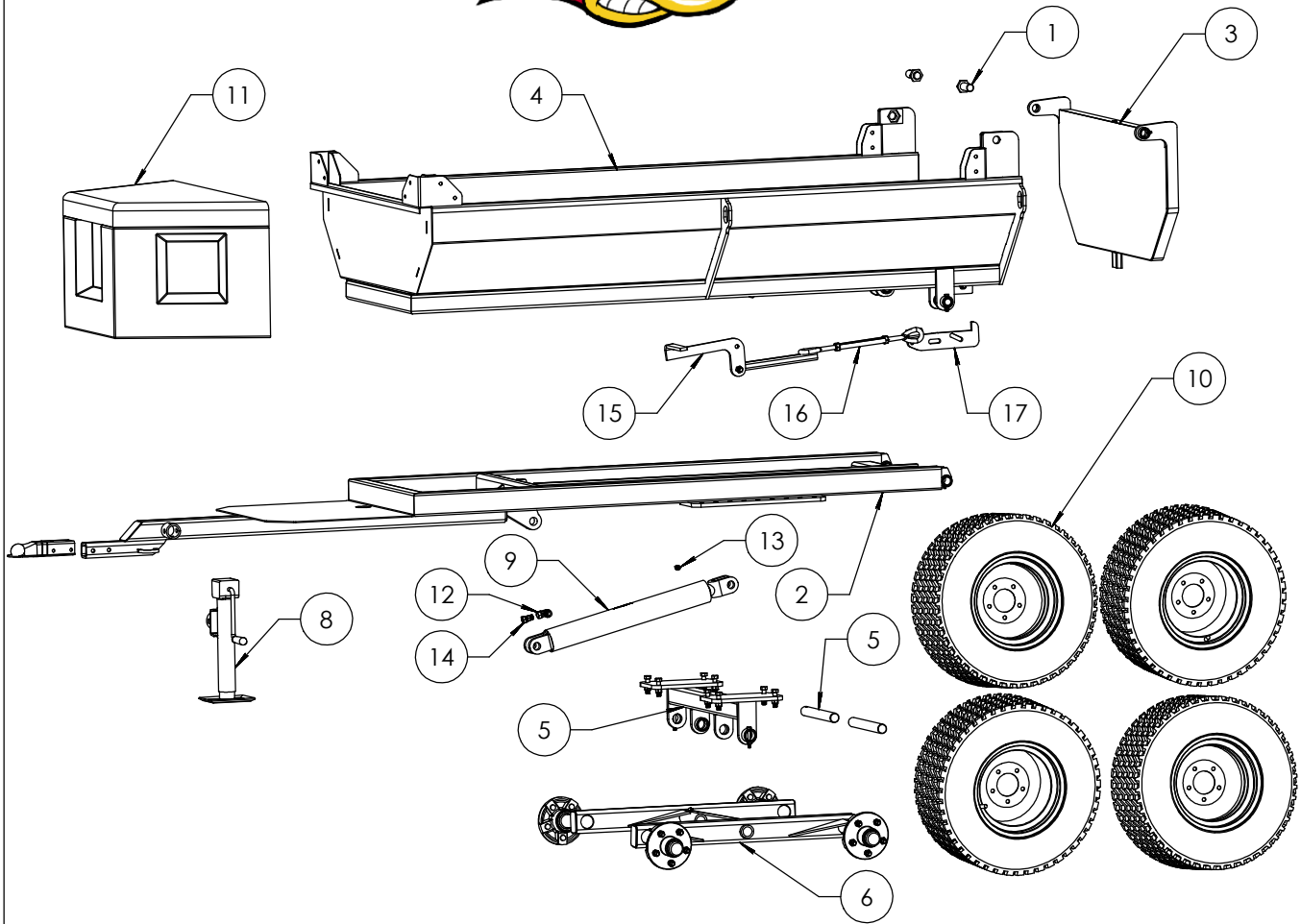

Dump Trailer, model 407 Parts list

Item	Part #	Description	Qty
1	59-035-08	Gravel box hinge panel pin	2
2	59-035-01	Frame	1
3	59-035-05	Rear panel	1
4	59-035-03	Gravel box	1
5	59-035-02	Axle	1
6	59-035-04	Tandem with hub 3500 LBS	2
7	310670	Hitch	1
8	303010	Jack-3000-2000 lbs	1
9	120331	Hydraulic cylinder HCL 2518	1
10	302200	Tires 23-10.5-12 6 ply 5 nuts	4
11	123000	Electric power Unit 12 volts 4 gallons with box	1
12	101420	90° - Male ORB Ajustable elbow 1/2" - Female NPSM 3/8" Swivel	1
13	102820	1/2 NPT Plug	1
14	103230	3/8" NPTFS adaptor-3/8" NPTM restrictor 1/16" dia.	1
15	59-035-033	Trigger lever	1
16	43070	Turnbuckle 5/8" Dia. X 6" Long	1
17	59-035-031	Rear lock	1

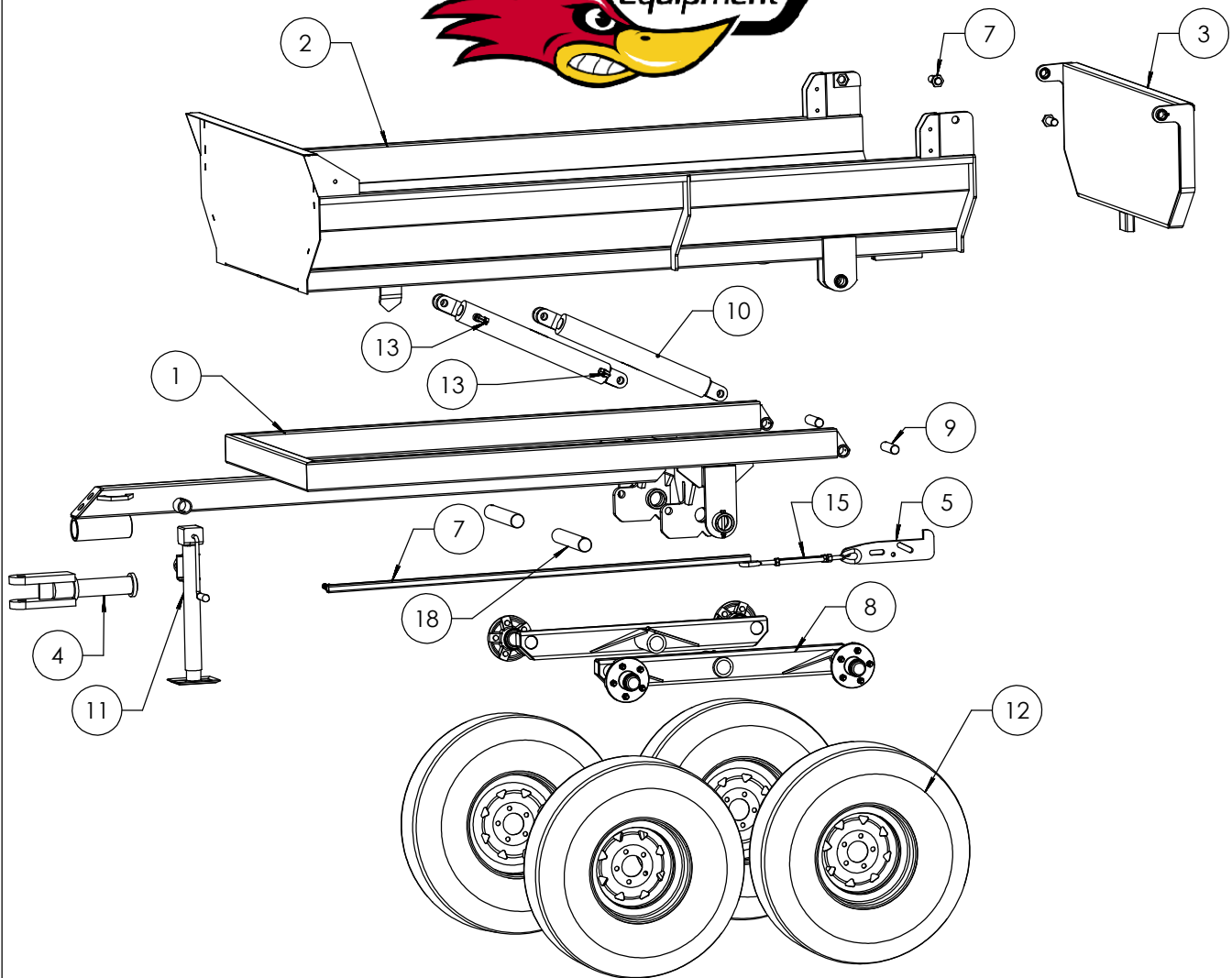

Dump Trailer, model 408 Parts List

Item	Part #	Description	Qty
1	59-501-02	Frame	1
2	59-501-03	Gravel box	1
3	59-501-04	Rear panel	1
4	59-003-08	Hitch	1
5	59-003-017	Rear lock	1
7	59-501-05	Dump trailer trigger arm	1
7	59-035-08	Gravel box hinge panel pin	2
8	59-022-06	Tandem with hub 3500 LBS	2
9	86-20-72-E08-00	Shaft 1-1/4" O.D.	2
10	120331	Hydraulic cylinder HCL 2518	2
11	303020	Jack-6000 or (5000) lbs	1
12	302000	Tires 11L15 8 ply 5 Nuts 3500lbs	4
13	101420	90° - Male ORB ajustable elbow 1/2" - Female NPSM 3/8" swivel	4
14	43070	Turnbuckle	1
18	86-31-189-F12-00	Shaft 1 15/16" O.D.	2

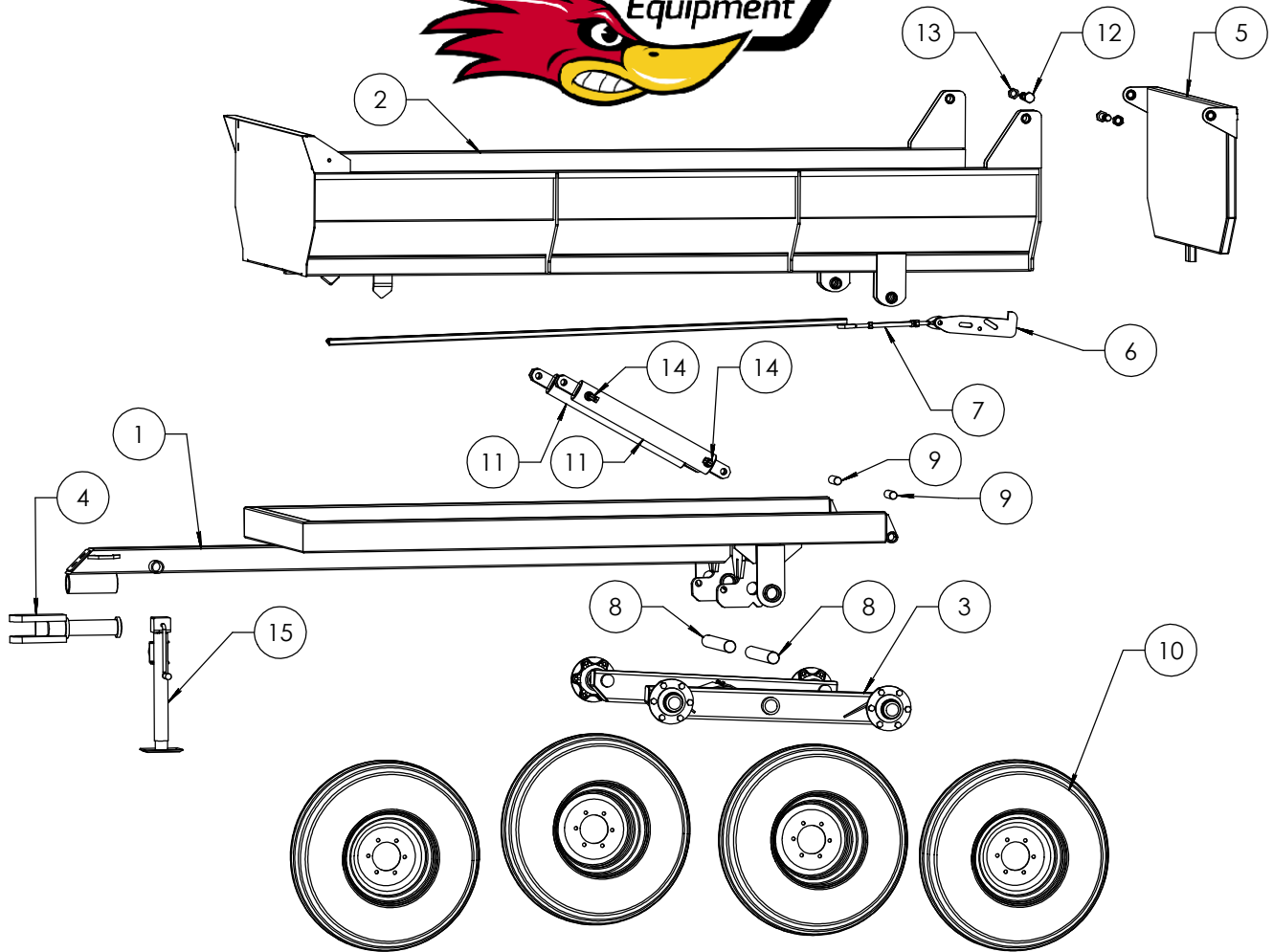

Dump Trailer, model 510 Parts List

Item	Part #	Description	Qty
1	59-500-02	Frame	1
2	59-500-03	Gravel Box	1
3	59-003-07	Tandem with hub 5000 lbs	2
4	59-003-08	Hitch	1
5	59-500-04	Rear panel	1
6	59-003-017	Rear lock	1
7	59-500-05	Dump trailer trigger arm 10'	1
8	86-31-291-F12-00	Shaft 1 15/16" O.D.	2
9	86-20-72-E08-00	Shaft 1 1/4" O.D.	2
10	302010	Tires 11L-15 8 ply 6 nuts 5000 lbs	4
11	120501	Hydraulic cylinder HCL 30 X 20	2
12	300310	Bolt 1"-8 x 5" Long	2
13	301500	Nylon nut 1"-8	2
14	101420	90° - Male ORB adjustable elbow 1/2" - Female NPSM 3/8" Swivel	4
15	303020	Jack-6000 ou (5000) lbs	1

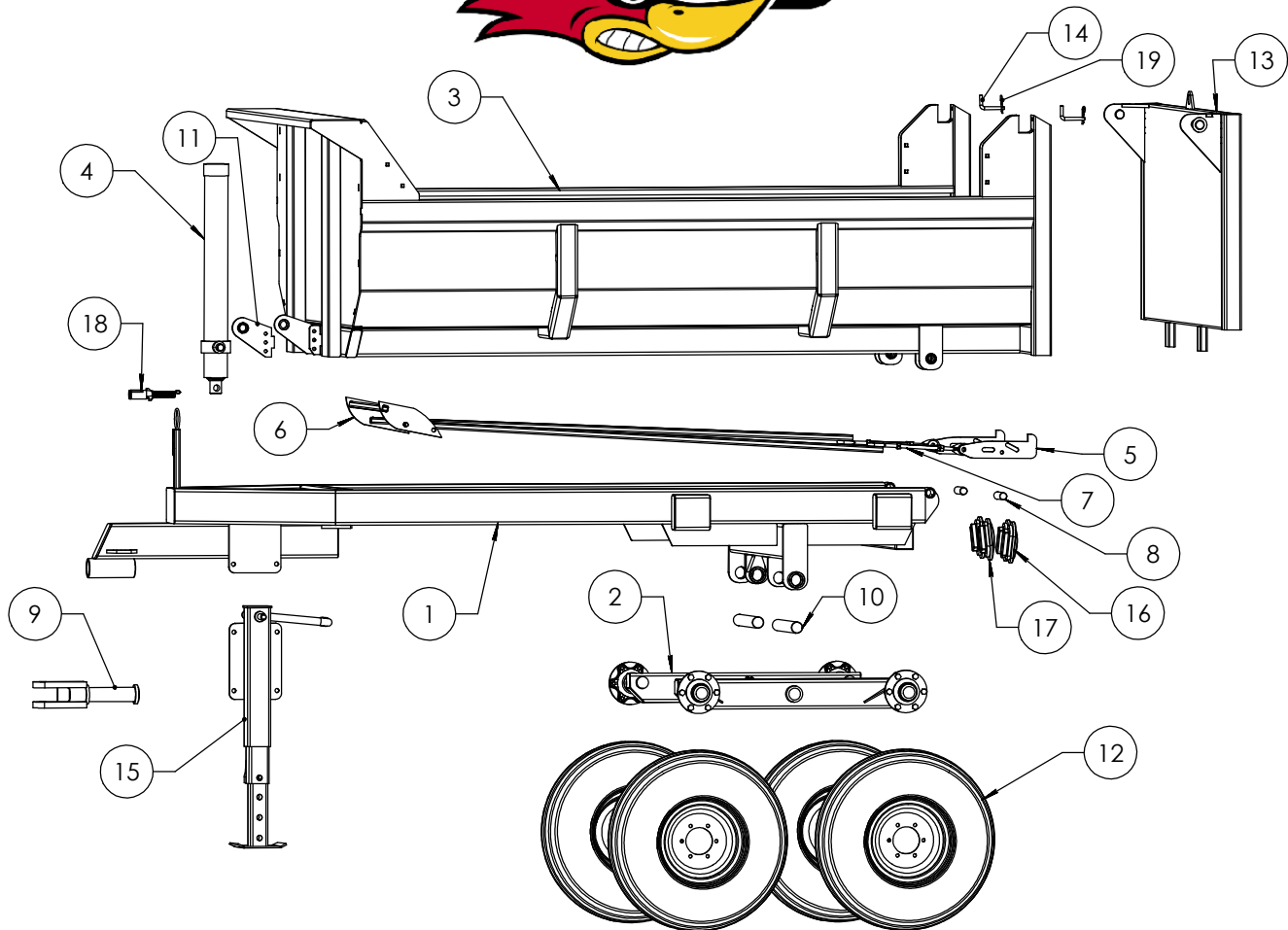

Dump Trailer, model 610 Parts list

Item	Part #	Description	Qty
1	59-121-01	Frame	1
2	59-003-07	Tandem with hub 5000 lbs	2
3	59-121-02	Gravel box 6 x 10	1
4	121110	Telescopic cylinder 90" stroke, 7 tons	1
5	59-003-017	Rear lock	2
6	59-121-05	Dump trailer lever	1
7	59-121-04	Dump trailer trigger arm 10'	2
8	86-20-90-E08-00	Shaft 1 1/4" O.D.	2
9	59-003-08	Hitch	1
10	86-31-285-F12-00	Shaft 1 15/16" O.D.	2
11	59-121-06	Cylinder attachment removable ear plate for 7 tons	1
12	302010	Tires 11L-15 8 ply 6 nuts 5000 lbs	4
13	59-121-03	Dump trailer Rear panel	1
14	59-114-062	Rear panel lock	2
15	59-112-19	Jack assembly 12000 lbs	1
16	310500	6.5 oval light (Yellow)	2
17	310510	6.5 oval light (Red)	2
18	310820	7-Pin-contact connector, side of trailer	1
19	310832	RK Pin 3"	2

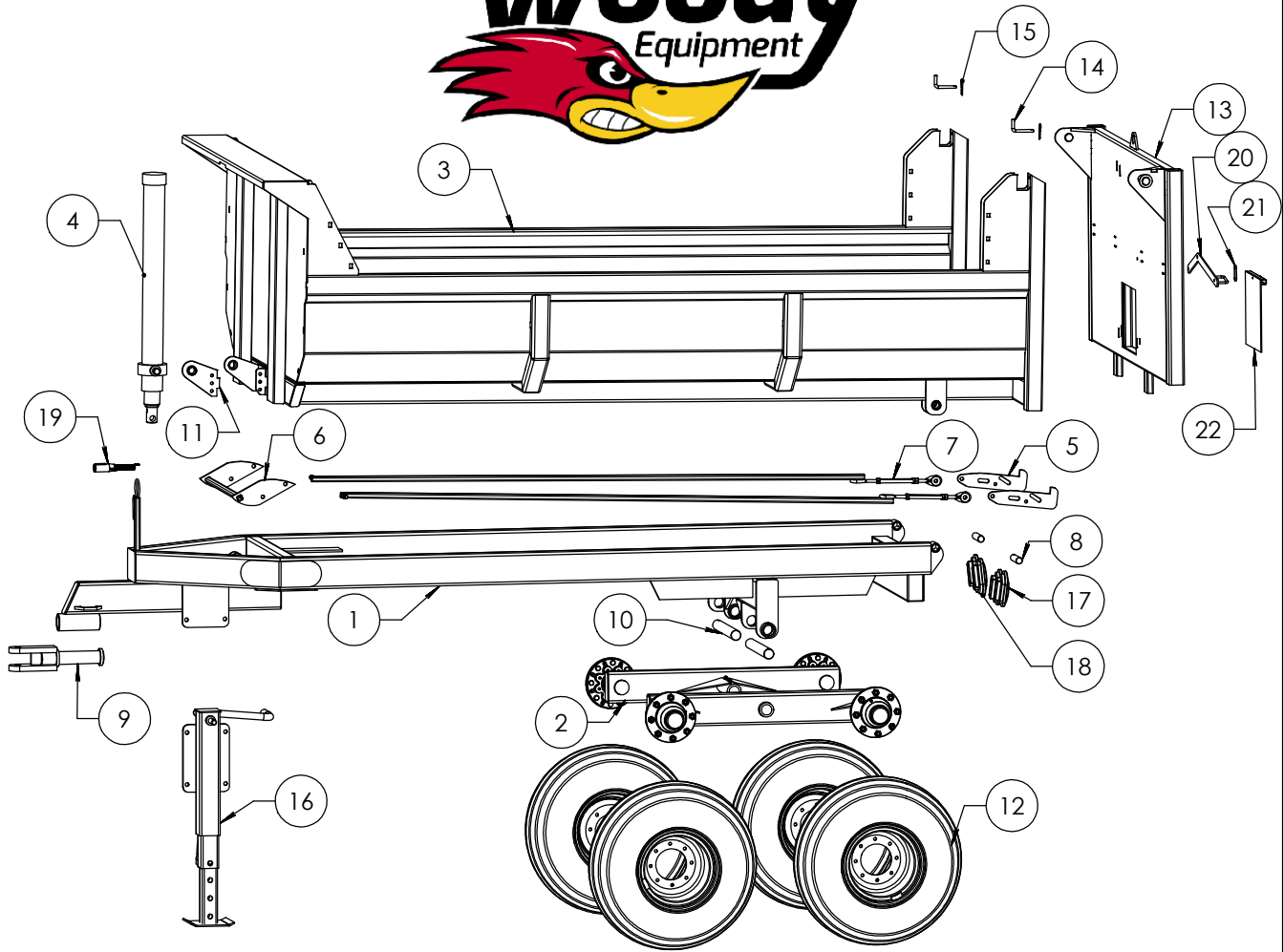

Dump Trailer, model 612 Parts List

Item	Part #	Description	Qty
1	59-122-01	Frame	1
2	59-082-07	Tandem with hub 8000 lbs	2
3	59-122-02	Gravel box	1
4	121120	7-ton Telescopic cylinder 108 inch stroke	1
5	59-003-017	Rear lock	2
6	59-121-05	Dump trailer lever	1
7	59-122-04	Dump trailer trigger arm 10'	2
8	86-20-90-E08-00	Shaft 1 1/4" O.D.	2
9	59-003-08	Hitch	1
10	86-31-285-F12-00	Shaft 1 15/16" O.D.	2
11	59-122-07	Cylinder attachment removable ear plate for 7 tons	1
12	-----	Tires 8 nuts 12.5L-15 / 400-60-15.5	4
13	59-122-05	Dump trailer rear panel	1
14	59-114-062	Rear panel lock	2
15	310832	RK Pin 3"	2
16	59-112-19	Jack assembly 12000Lbs	1
17	310500	6.5 oval light (Yellow)	2
18	310510	6.5 oval light (Red)	2
19	310820	7-Pin-contact connector, sedi of trailer	1
20	59-114-20	Grain door handle	1
21	59-111-072	Grain door handle pin	1
22	59-111-21	grain door	1

Les équipements
Woody
Equipment

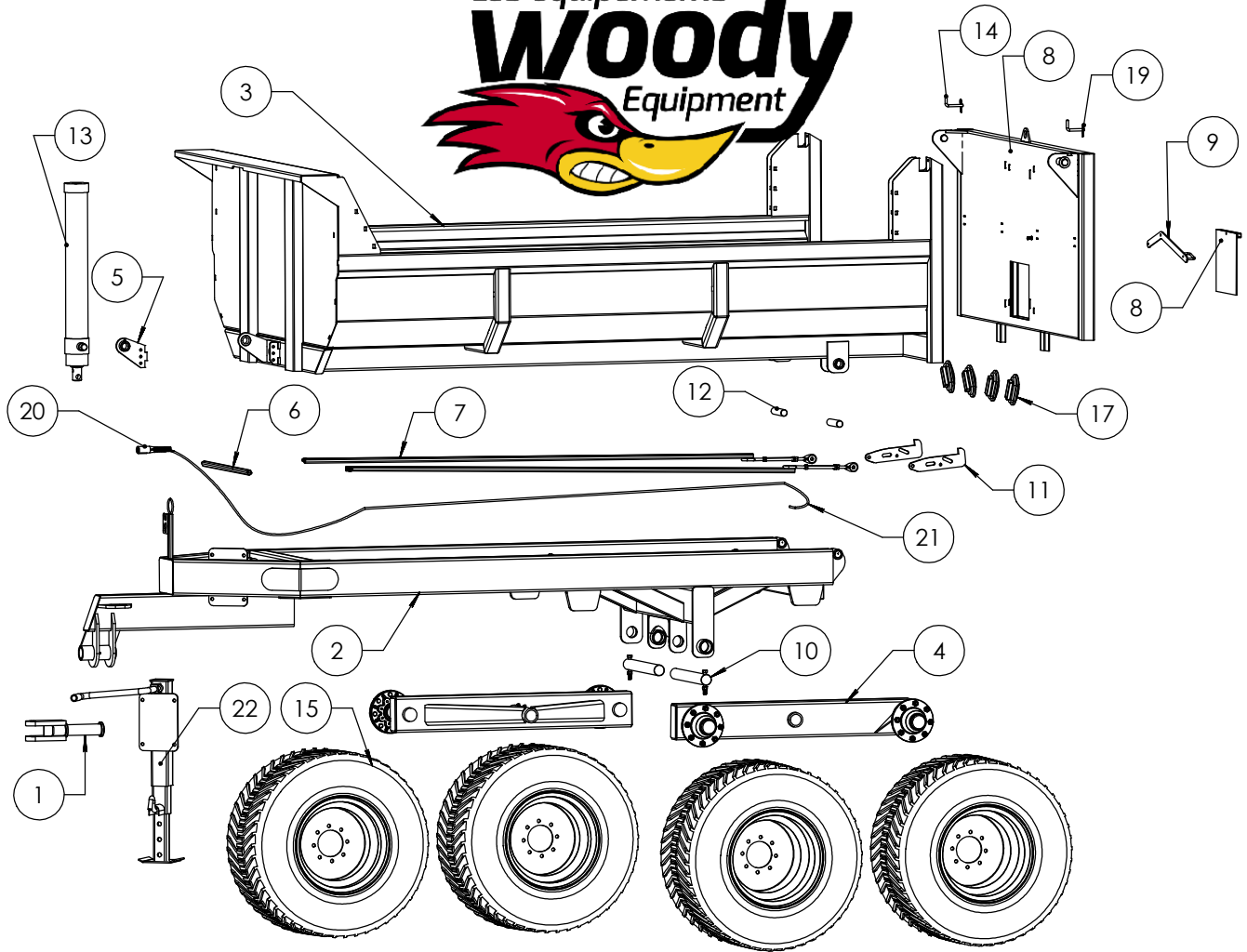

Dump Trailer, model V712 Parts List

Item	Part #	Description	Qty
1	59-109-15	Hitch	1
2	59-114-01	Frame	1
3	59-114-03	Gravel box	1
4	59-114-04	Tandem with hub 8000 lbs	2
5	59-114-07	Cylinder attachment removable ear plate for 12 tons	1
6	59-114-09	Dump trailer lever	1
7	59-114-10	Dump trailer trigger arm	2
8	59-114-14	Dump trailer rear panel	1
9	59-114-20	Grain door handle	1
10	86-39-357-J16-00	Shaft 2 7/16" O.D.	2
11	59-003-017	Rear lock	2
12	86-24-114-E08-00	Shaft 1 1/2" O.D.	2
13	121130	12-ton telescopic cylinder 108 inch stroke	1
14	59-114-062	Rear panel lock	2
15	-----	Tires 8 nut 550-45-22.2 / 400-55-22.5 / 425-65-22.5 / 16.5L16.1	4
16	310510	6.5 oval light (Red)	2
17	310500	6.5 oval light (Yellow)	2
18	140040-102-101700-101700	Hose 1/2"	1
19	310832	RK Pin 3"	2
20	310820	7-Pin-contact connector, side of trailer	1
21	310800	Electric line	1
22	59-112-19	Jack 12000Lbs	1

Les équipements
Woody
Equipment

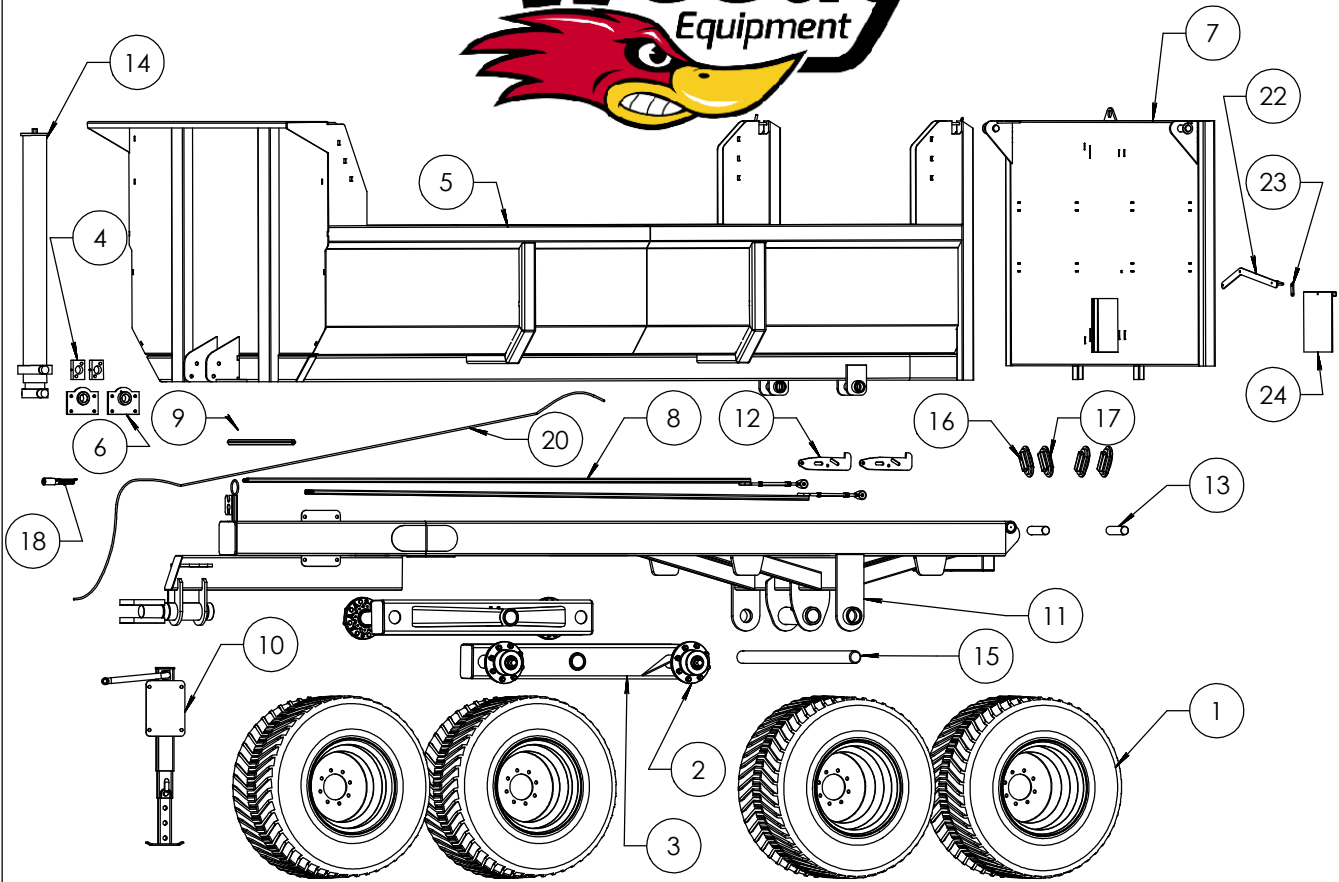

Dump Trailer, model V814 parts list

Item	Part #	Description	Qty
1	302100 or 302120	Tires 550-45-22.2 or Tires 600-55-22.5	4
2	306501 ou 306801	Hub 12 000lbs or Hub 16 000lbs	2
3	59-120-06 ou 59-172-05	Tandem 59-120-06 or Tandem 59-172-05	2
4	121170	PB3005002	2
5	59-120-03	Gravel box	1
6	59-120-05	Cylinder lock	2
7	59-120-14	Dump trailer rear panel	1
8	59-120-10	Dump trailer trigger arm	2
9	59-120-09	Dump trailer lever	1
10	59-112-19	Jack 12000Lbs	1
11	59-120-01	frame	1
12	59-003-017	Rear lock	2
13	86-31-124-F12-00	Shaft 1 15/16" O.D.	2
14	121150	20-Ton telescopic cylinder 135 inch stroke	1
15	59-120-073	Shaft 2- 15/16" O.D.	1
16	310500	6.5 oval light (Yellow)	2
17	310510	6.5 oval light (Red)	2
18	310820	7-Pin-contact connector, side of trailer	1
19	310832	RK Pin 3"	2
20	310800	Electric line	1
21	59-114-20	Grain door handle	1
22	59-111-072	Grain door	1
23	59-111-21	Grain door	1

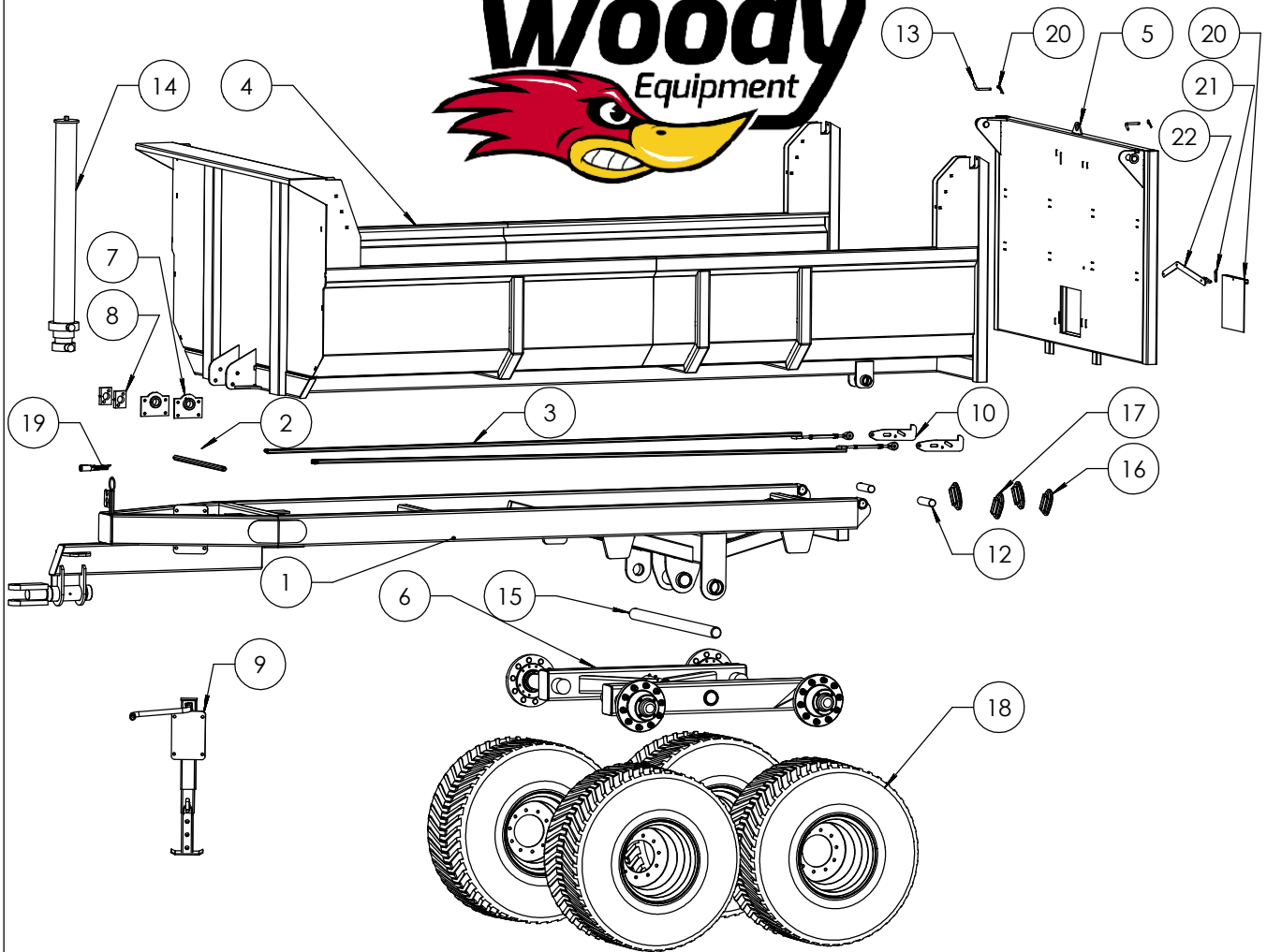

Dump Trailer model V816 Parts list

Item	Part #	Description	Qty
1	59-124-01	Frame	1
2	59-124-09	Dump trailer lever	1
3	59-124-10	Dump trailer trigger arm	2
4	59-124-03	Gravel box	1
5	59-120-14	Dump trailer rear panel	1
6	59-124-11	Tandem with hub 16000 lb	2
7	59-120-05	Cylinder lock	2
8	121170	PB3005002	2
9	59-112-19	Jack 12000Lbs	1
10	59-003-017	Rear lock	2
12	86-31-124-F12-00	Shaft 1 15/16" O.D.	1
13	59-114-062	Rear panel lock	2
14	121160	20 Ton telescopic single action 150 inch stroke	1
15	59-124-033	Shaft 2- 15/16" O.D.	1
16	310500	6.5 oval light ,KT3260A (Yellow)	2
17	310510	6.5 oval light ,KT3260R (Red)	2
18	302120	Tires 600-55-22.5 10 nuts	4
19	310820	7-Pin- contact connector, side of trailer	1
20	310832	RK Pin 3"	2



Dump trailer Gravel box Extensions

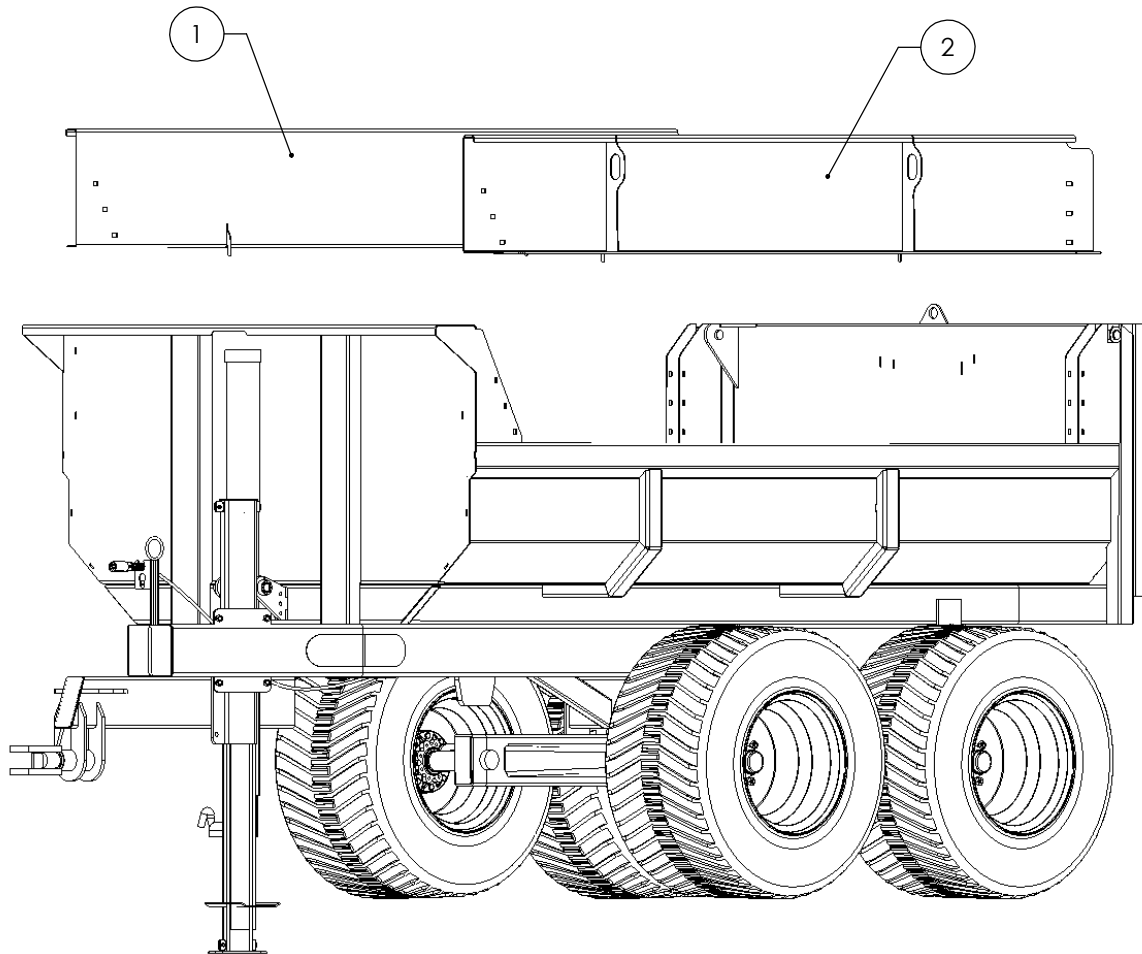

Item	Dump Trailer	Part #	Description	Height	Qty
1	V 612	59-114-16	Right panel	18.25"	1
2	V 612	59-114-15	Left panel	18.25"	1
1	V 712	59-114-16	Right panel	18.25"	1
2	V 712	59-114-15	Left panel	18.25"	1
1	V 814	59-112-11	Right panel	24"	1
2	V 814	59-112-11	Left panel	24"	1
1	V 816	59-129-16	Right panel	24"	1
2	V 816	59-129-15	Left panel	24"	1



Dump trailer Gravel box High extensions

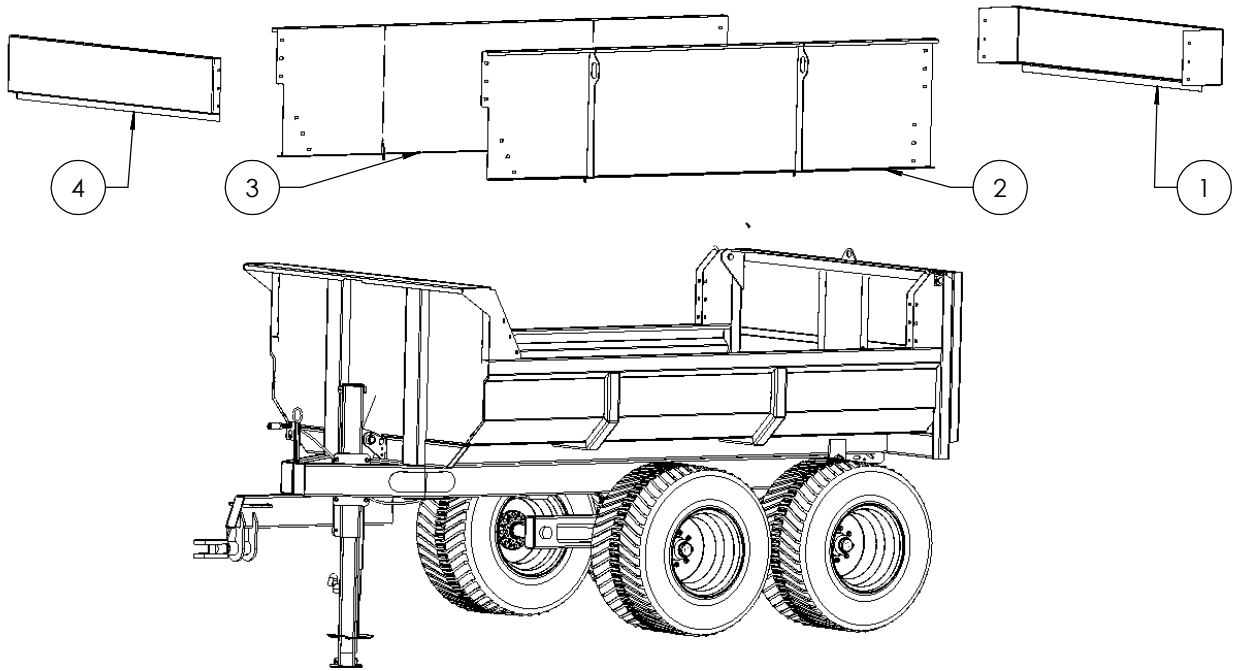

Item	Part #	Model #	Description	Height	Qty
1	59-122-026	V 612	Rear panel	14"	1
2	59-114-17	V 612	Left side panel	32.25"	1
3	59-114-18	V 612	Right side panel	32.25"	1
4	59-122-025	V 612	Front panel	14"	1
1	59-114-093	V 712	Rear panel	14"	1
2	59-114-17	V 712	Left side panel	32.25"	1
3	59-114-18	V 712	Right side panel	32.25"	1
4	59-114-092	V 712	Front panel	14"	1
1	-----	V 814	Rear panel	If needed	1
2	-----	V 814	Left side panel	If needed	1
3	-----	V 814	Right side panel	If needed	1
4	-----	V 814	Front panel	If needed	1
1	-----	V 816	Rear panel	If needed	1
2	-----	V 816	Left side panel	If needed	1
3	-----	V 816	Right side panel	If needed	1
4	-----	V 816	Front panel	If needed	1



Operation

General safety rules:

Read this instruction manual carefully before using the dump trailer. The technical data in this manual contains important information. Improper use can result in injury and damage to the equipment.

Woody dump trailers are intended for normal use in the agricultural and forestry sectors. They must be used only by persons trained in the handling of this type of machinery.

- . Before connecting the dump trailer to the tractor's hydraulic system, you must read the tractor's instruction manual to ensure proper connections.
- . Be extremely careful when connecting the dump trailer to the tractor or the trailer to the tractor, as well as when detaching it.
- . When operating, make sure everyone remains in the safety zone, outside of the loader risk area. The user and operator of the excavator must have full visibility of the work area..
- . When operating, do not insert your hand or any other part of your body into the machine or under the load. Do not risk getting stuck between the different parts of the dump trailer or between the tractor and the dump trailer.
- . Do not forget to lower the gravel dump box before moving the trailer.
- . When loading, always engage the tractor handbrake.
- . Never use the dump trailer to pull, push or hit.
- . Be particularly careful when loading and unloading heavy materials.
- . Never use the loading device during transport.
- . To stop the machine, turn off the engine, engage the handbrake and remove the key from the ignition to prevent unauthorized use
- . The dump trailer is not intended for transporting people.
- . Be very careful when loading or unloading near high voltage lines. Keep a safe distance from live cables.



Safety Instructions

If the overload protection of the hydraulic system is not properly adjusted or certain system functions are altered, safety cannot be ensured.

- . Always check that any unauthorized personnel remains outside the work risk area.
- . Make sure that the tractor and trailer are always on firm ground so that there is no risk of overturning when loading or unloading.
- . Make sure you always have a visual view of the work area.
- . Do not work in conditions where you may get your fingers caught or hurt yourself.

When there is a risk of overturning, immediately lower the gravel box with the control lever.

- . Hold the lever in this position until the load is on the ground. Do not interrupt the lowering movement as the risk of overturning will increase if the load stops abruptly.
- . If the tractor rolls over, follow the instructions in the cab. Do not jump out of the cab. You could end up under the load during a fall or under the tractor.

Cracks in hydraulic hoses

- . In the event of pressure loss in the hydraulic fluid or cracks in the hydraulic hoses, you must immediately shut down the tractor engine and lower the dump trailer gravel box to the ground. Stop the hydraulic flow. Repair the leak
- . If the main pressure hose is cracked, you must interrupt the oil flow by disconnecting the lever control associated with the tractor's hydraulic distributor or by shutting off the engine with the OFF button.



Safety Instructions

Driving on the Road

Observe the following instructions to avoid any risk of accident

Position during Transport

Make sure that the dump trailer is firmly attached to the transportation trailer, so that it does not fall off during transport.

. Make sure that no additional equipment connected to the dump trailer is likely to cause an accident during transport.

Control is Important

. You must constantly be in control of the dump trailer at all times and in all situations.

. Check that the "slow vehicle" plate and the reflective signals are correctly positioned. Check if the trailer lights are functioning correctly and check the tire pressure.

. The total permitted weights (in particular the weight of the axle) and the transport dimensions must never be exceeded.

. You must adapt your speed to the driving situation. Drive with caution when one side is tilted, as well as on sloping ground. There is a risk of over turning.

. Respect the laws of the road and applicable regulations.

. The braking distance of a tractor equipped with a trailer is longer than for other vehicles, beware of the risk of skidding and check for irregularities in the road.

. Secure the load and other loose parts securely.

Oil and Grease Caution

. Avoid any oil or grease contact with the skin during maintenance. Wear appropriate protective clothing.

. Never wash your hands with lubricating oil or grease. It may damage your skin. If your skin is irritated after contact with oil or grease, contact a doctor immediately.

. When servicing, waste oil should be disposed of in accordance with local regulations.



Safety Instructions

Welding Repair

. If a repair or modification requires the welding of certain parts, you must first contact your dealer for necessary instructions. Improper welding or negligence during welding can cause sudden machine breakdowns.

Working in Extreme Conditions

. The recommended ambient temperature for the operation of this machine is between -20 °C and + 30 °C. Low or high temperatures result in increased wear and stress on joints and hoses. In addition, steel wears faster, and cracks can occur.

. When working in extreme conditions, reduce loads to prevent damage. In case of low temperature let the hydraulic oil circulate freely during several minutes. Then operate each function several times to soften the joints and hoses before applying full pressure. When it is extremely hot, pay attention to the oil temperature. A temperature above 80 °C alters the properties of the oil and damages joints and hoses.

Maintenance / Service

. Regular maintenance and service ensure optimal and cost effective operation.

. Note: Failure to follow the instructions in this manual will void all warranties related to this dump trailer. Regular and proper maintenance are a prerequisite for warranty coverage.

Maintenance and Servicing Safety Instructions

. Read the instructions before servicing the machine. Each maintenance task requires reading and following instructions. Maintenance and lubrication should be done at the recommended intervals.

. Always use tools suitable for the maintenance / servicing tasks involved. Wear protective clothing and glasses.

. Shut off the tractor engine and remove the ignition key. If the engine has to run during certain maintenance operations, please stay away from any moving parts of the machine.

. Be extremely careful with pressurized oil. Oil under high pressure easily penetrates the skin. In case of accident, consult a doctor immediately.



Safety Instructions

Maintenance and Servicing Safety Instructions (...continued)

- . Hot oil can cause burns. Inhalation of hot oil vapor can cause breathing difficulties.
- . If a hose bursts and you get oil on your skin, it is not dangerous. However, avoid oil contact with eyes and nose. If you get oil in your eyes or in your respiratory tract, contact a doctor immediately.
- . Keep explosive and flammable liquids away from sparks and open flames.

Daily inspections

It is important to inspect the equipment daily. If you notice a defect, you must repair it immediately.

- . When under load pressure, worn bolts can provoke a risk of rupture. If cracks are detected on the loader, any operation in progress must be stopped immediately.
- . Damaged hoses must be replaced immediately. Check for leaks. Oil leaks create a risk of accidents and can harm the environment.
- . Check the bolts and tighten the bolts if necessary.
- . Perform the various movement patterns of the loader to verify that all functions are intact and working properly.

Les équipements
Woody
 Equipment
Safety Instructions

Greasing schedule

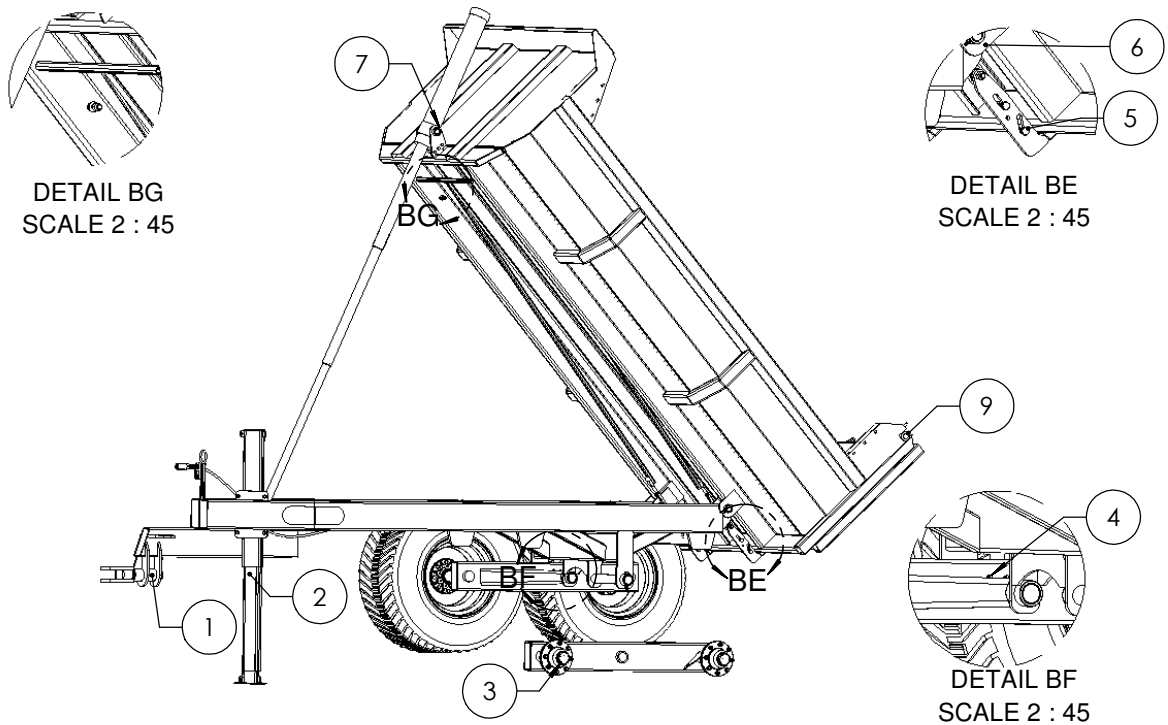

ITEM	Greasing point	Lubricating oil	Greasing interval Hourly / yearly
1	Swivel hitch	Bushing grease	Every 5 hours
2	Jack	Bushing grease	Once a year, generously
3	Hub	Bearing grease	Every 10 hours
4	Tandem pivot	Bushing grease	Every 5 hours
5	Trigger slider	Bushing grease	Once a year, generously
6	Gravel box pivot	Bushing grease	Every 5 hours
7	Cylinder pivot	Bushing grease	Every 5 hours
8	Trigger slider pivot	Bushing grease	Once a year, generously
9	Panel pivot	Bushing grease	Every 5 hours



Storage

If you plan to stop using the dump trailer for a long period of time, it should be cleaned carefully. Note that high pressure cleaning is not recommended! After cleaning, make a visual inspection for any cracks (if you find any, you must have them repaired before the next use of the loader) all grease nipples must be lubricated. The grease is used to evacuate water and thus neutralize corrosion and wear.

. Store the dump trailer under a roof. If this is not possible, cover it with a tarpaulin.

Note: A stored trailer is not a play area for children.



1-YEAR LIMITED WARRANTY

Warranty Qualifications

All Products manufactured by Woody and used for domestic purposes (excluding commercial, industrial or abusive use) are covered by a one (1) year warranty applicable from the purchase date, except in particular cases when the warranty might be modified according to adjustments specified on the sales contract.

The warranty extends only to the original purchaser of the Product and not to other purchasers or transferees unless agreed to in writing by Woody that the mechanical and electrical components will be free of defects in material and workmanship for the warranty period. The warranty covers all the parts of the new Product, except the hydraulic hoses, the hydraulic fittings and the electrical wires, and includes the labor performed by Woody or by a Woody authorized Dealer.

Warranty Repair and Replacement Service

All warranted repairs must be performed by Woody or by an authorized Dealer with the written consent of Woody; otherwise the warranty will be voided. Woody reserves the right to either repair or replace, without cost to the buyer any part judged defective on grounds of defective materials or workmanship. It also reserves the right to determine if the defect resulted from lack of maintenance or incorrect or abusive use of the Product.

In the event of any failure caused by a defect in material or in factory workmanship covered by this warranty, the Buyer shall: (1) notify Woody of the nature of the problem without delay; (2) stop using or operating the Product unless authorized in writing by Woody.

Warranty service shall be performed at the point of purchase of the Product either by Woody or by a Dealer using parts provided by Woody.

If the Product was purchased directly from Woody, the Buyer shall return either the Product or the defective parts "prepaid" to Woody without delay. If Woody deems that the parts are in fact defective, it shall repair or replace the parts and, when the Product is returned to Woody, install them free of charge to the Buyer.

If the Product was purchased from a Dealer, Woody shall provide the replacement parts to the Buyer through the intermediary of the Dealer. The Dealer shall install the parts and return the replaced parts to Woody, "prepaid" by the Buyer, within thirty (30) days of the repairs. The parts and their installation shall be without charge to the Buyer providing that the replaced parts are proven defective to Woody's satisfaction.

In all cases, all costs related to the transportation of parts or of the Product to and from Woody or the Dealer, any premium charged for overtime labor requested by the Buyer or for any service and/or maintenance shall be the sole responsibility of the Buyer.

All parts replaced under the warranty shall remain the property of Woody.

If the Buyer fails to follow any of the above procedures or if the parts are not proven to be defective to Woody's satisfaction, the Buyer shall not benefit from the warranty.



No Dealer Warranty

The Dealer has no authority to make any representation or promise on behalf of Woody, or to modify the terms or limitations of this warranty in any way.

Warranty Exclusions

This warranty does not cover the following:

Product needs periodic parts and service to perform well. This warranty does not cover repair when normal use has exhausted the life of a part or the equipment as a whole or by lack of reasonable and proper maintenance, by lack of proper protection during storage, by failure to follow operating instructions and/or failure to operate the Product according to the specifications outlined by Woody.

This warranty does not apply to damage caused to the Product or machinery by the Buyer or Dealer during installation of the Product or due to improper installation of the Product.

This warranty will not apply to parts and/or labor if this Product is deemed to have been misused, neglected, involved in an accident, abused or defects caused by any alteration or modification of the Product not approved in writing by Woody.

This warranty does not cover travel time and does not cover any other transportation-related costs for warranty repairs or for any other expertise.

Other Exclusions

This warranty excludes:

- Cosmetic defects such as paint, decals, etc.
- Any damage resulting from overturning the machine.
- Failures due to acts of God and any other major force events beyond Woody's control.
- Problems caused by parts that are not original Woody parts.
- Certain parts are guaranteed by their respective manufacturer.

Limits of Implied Warranty and Consequential Damage

Woody disclaims any obligation to cover any material or personal damages, including loss of time, loss of income use of this Product, replacement rental, freight or any other damages caused by a defective Product or any incidental or consequential claim by anyone from using this Product.