

Rem

DELTA

**3 - POINT
FLEXIBLE
HARROW**

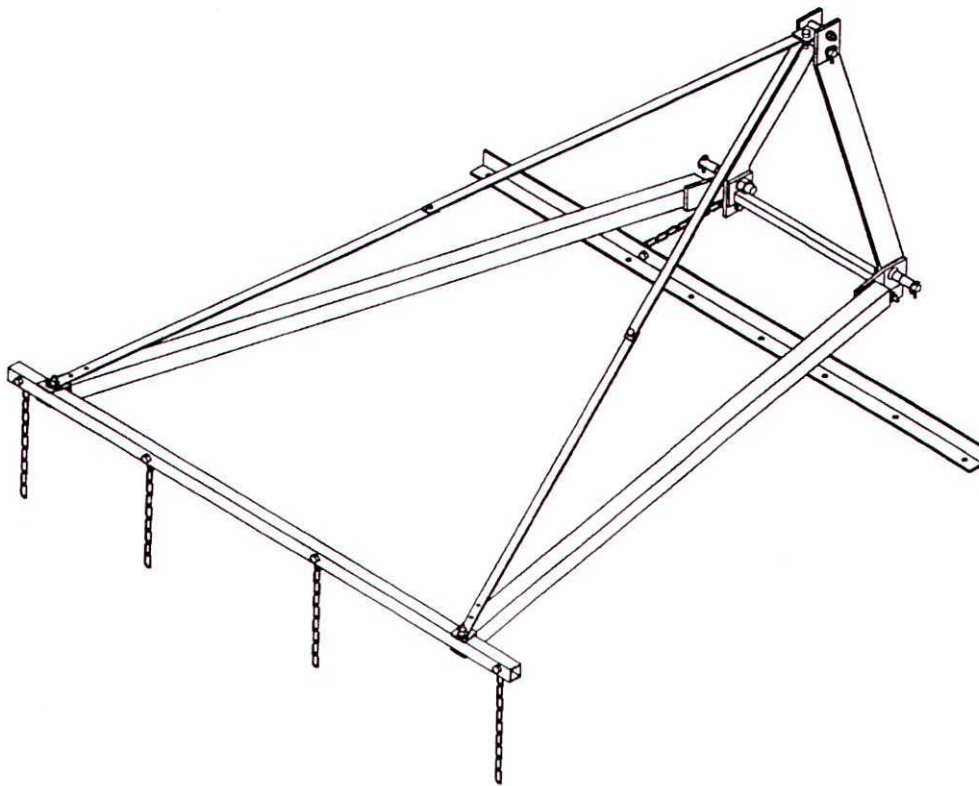

OWNERS MANUAL

10-104352

ASSEMBLY INSTRUCTIONS

1. LAY HARROW FLAT IN DESIRED POSITION : AGGRESSIVE, NON AGGRESSIVE OR BACKSIDE.
2. CONNECT HARROW TO DRAW BAR HOOKS THROUGH HOLES.
3. BOLT CHAIN BRACKET (D) BETWEEN 3 pt. FRAME ASSEMBLY (A).
4. PLACE HITCH PIN (G) THROUGH LIFT ARM (C), SLIDE HITCH PIN (G) THROUGH THE HOLES IN 3 pt. FRAME (A) ALSO 3 pt. SUPPORT BRACE (B).
5. BOLT SUPPORT BAR (H) AND (T) AND REAR LIFT BAR (F) TO LIFT ARM (C).
6. ATTACH PULL BAR (E) TO 3 pt. FRAME (A) WITH PULL CHAIN (J).
7. PLACE LIFT CHAIN (I) TO HARROW AS SHOWN IN DIAGRAM.
8. ADJUST REAR LIFT POSITION BY USING 3rd MEMBER ON TRACTOR.



CAUTION

STAY CLEAR OF HARROW WHEN LIFTING, LOWERING, AND TURNING. USE LIFT MECHANISM TO LIFT HARROW ONLY. DO NOT OVERLOAD. FRONT END WEIGHTS MAY BE REQUIRED ON LIGHTWEIGHT TRACTORS.

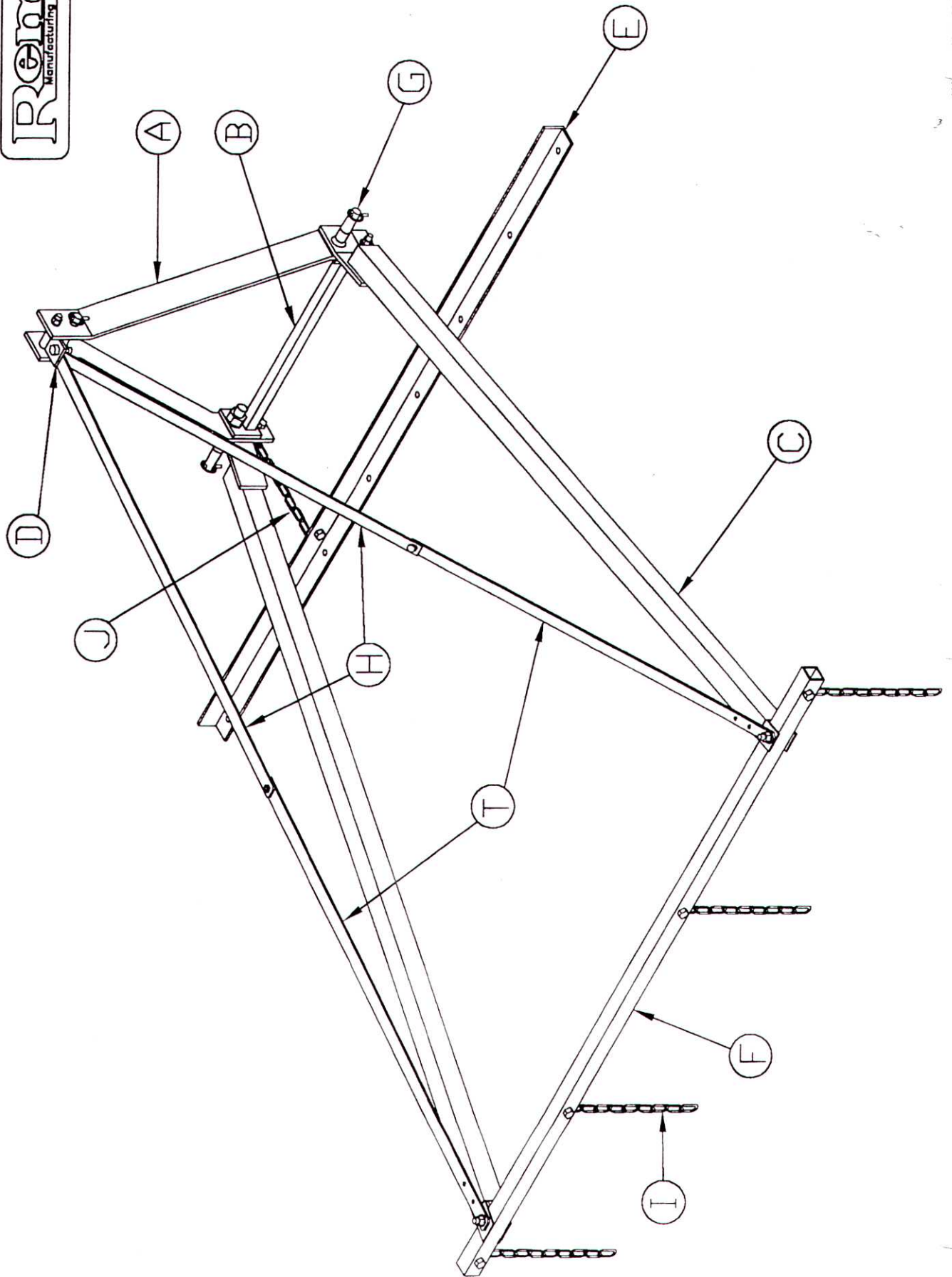

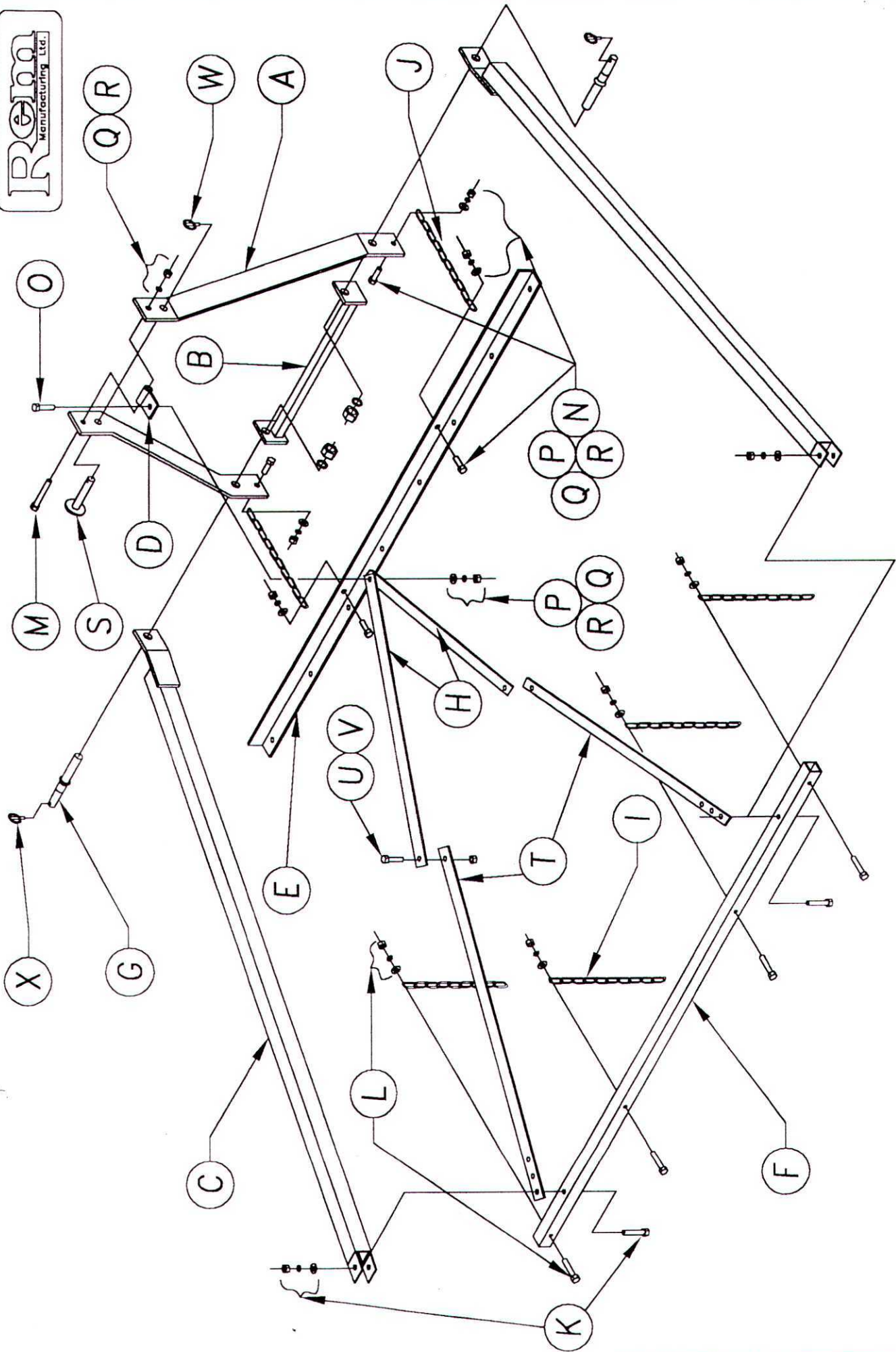

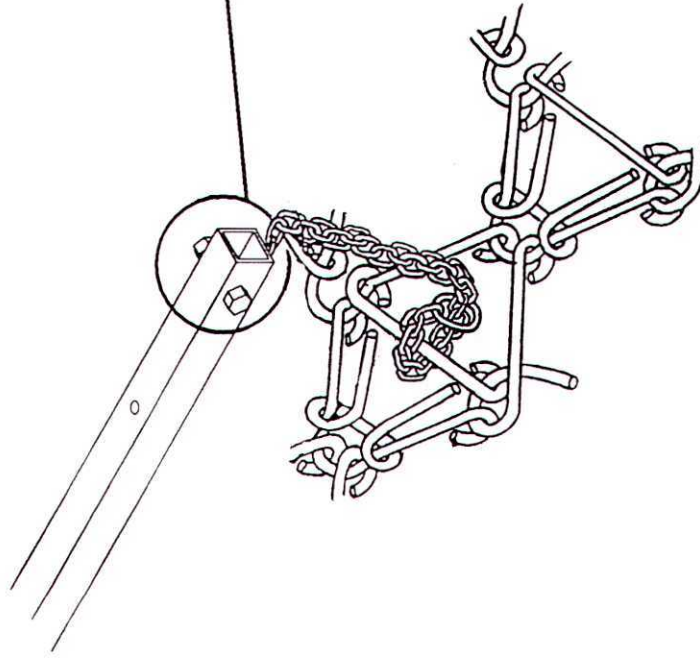
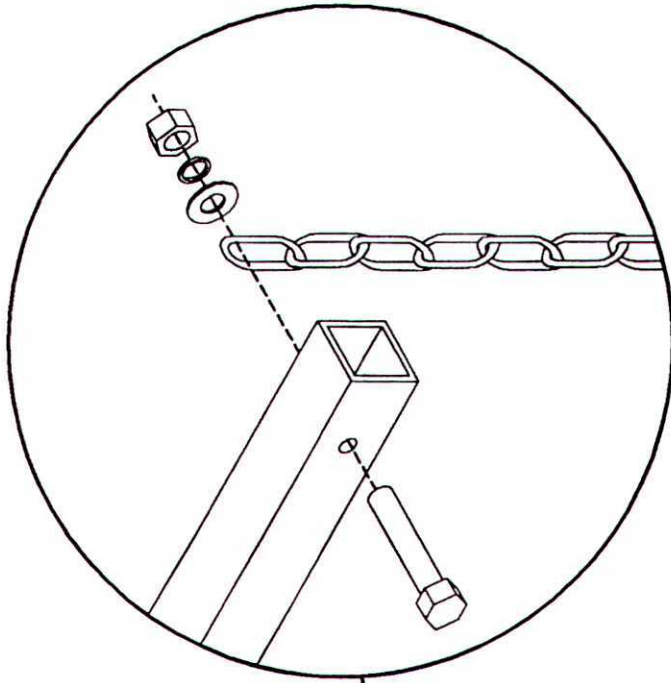

CHAIN LIFT ASSEMBLY INSTRUCTIONS

1. Wrap chain around the cross tie.
2. Thread the small end of the chain through the enlarged link on the opposite end.
3. Bolt small link of chain to the Delta Cart frame, putting the bolt in from the top, the tube, then the chain, flatwasher, and nut.

