

# FERRI<sup>®</sup>

Boom mowers for agriculture  
and green areas light green  
maintenance

**T380D**  
*SMART*

**T430D**  
*SMART*



# T380D

SMART

# T430D

SMART

Technological innovation and restyling characterize the hydraulic reach mowers T380D and T430D. The use of the polypropylene oil tank, allows a significant weight reduction, thus facilitating the hitching on the compact tractors. The new flail head TID100, 39" width uses the same rotor to fit multiuse Y, articulated Y

and hammers. A unique feature is the circular section of the arms (HTR High Torsion Resistance). The use of press molded components for the arm articulation as well as the electrical controls with joystick option make these compact reach mowers a valuable tool for farmers and landscapers.

Mechanical breakaway  
(arm protection in case of  
obstacles)

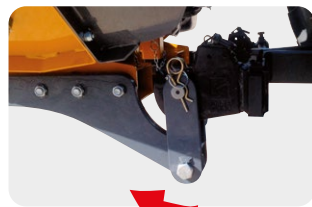
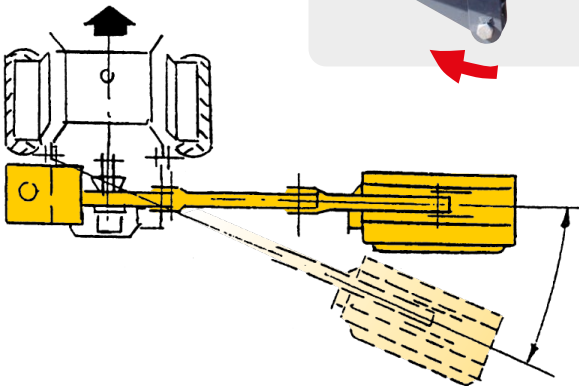

## Boom mowers for agriculture and green areas light green maintenance



Circular section of the arms H.T.R. (High Torsion Resistance)



Drop forged parts

# FERRI®



T 380D  
T 430D

## OPTIONAL



Lift float on the 1st arm by accumulator LFA

## IMPLEMENTS



Floating system.



**Classic**, cable controls.



**Electra Full**, monolever electric control with rotor's electric switch.



Cutter bar



Oil cooler with thermostat



# Boom mowers for agriculture and green areas light green maintenance



Technical data		T SMART		
Model		T 380D	T 430D	T 430DR
Max horizontal reach*	ft	12'7"	14'2"	14'2"
3 Points Linkage	Cat.	I - II	I - II	I - II
Weight	lbs	1080	1091	1091
Hydraulic oil	gal	18.5	18.5	18.5
P.t.o.	MAX Rpm	540	540	540

\*Reach measured from tractor centre line to head edge.

Flail head		TID100	
Cutting width	in	39"	
Rotor speed	Rpm	3000	
Blade tip speed	ft/sec	196	
Flail head angle		190°	
Weight	lbs	284	
Power available to the rotor	HP	20	
Power max to hydraulic motor	HP	34	



TID100 Direct Drive

Tractor							
HP/PS		40	50	60	70	Min. Tractor weight	Min. Tractor width
T 380D SMART						3747 lbs	4'11" ft
T 430D SMART						4409 lbs	5'6" ft
T 430DR SMART						4409 lbs	5'6" ft

Flails		N°
<b>TID100</b> Interchangeable on the same rotor		
Multi-use and straight blades for: grass, shrubs, bushes, sticks, wood.	Ø max 1" 1/4	36+18
Articulated Y blades for: grass and bushes	Ø max 3/4"	36
Bootie blades for: grass, hedges, bushes	Ø max 3/4"	18

Working positions (ft)				
		T 380D	T 430D	T 430DR
A	ft	12'7"	14'2"	14'2"
B	ft	7'11"	9'6"	9'6"
C	ft	3'9"	3'9"	3'9"
D	ft	7'4"	8'4"	8'4"
E	ft	13'9"	15'5"	15'5"
F	ft	2'10"	2'10"	2'10"
G	ft	5'0"	5'7"	5'7"
H	ft	11'2"	12'9"	12'9"

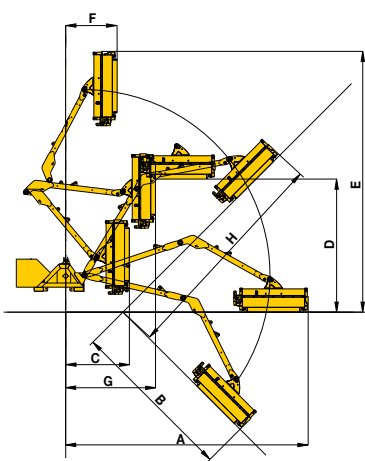

All data subject to change [campbelladv.com](http://campbelladv.com) 59220 T380D T430D - USA - EN Rev.1 - 500

[www.ferri-america.com](http://www.ferri-america.com)



**FERRI srl**  
Via Govoni, 30  
44034 Tamara (FE) Italy  
Tel. +39 0532 866866  
Fax +39 0532 866851  
info@ferri.it - www.ferri.it



**North America Sales and Marketing Manager / FERRI**  
Kent Zimmerman  
Cell (402) 677-3424  
k.zimmerman@ferri.it

**Parts Stock / FERRI:**  
J.S. Woodhouse Co., Inc. - 1314 Union Street  
P.O. Box 1169 - West Springfield, Ma. 01090 U.S.A.  
tel. 413-736-5462 - fax 413-732-3786  
info@jswoodhouse.com